

CENTAUR



FREE FLOW EXERCISER SERVICE MANUAL & INSTALLATION DIAGRAMS

5761 RIDGEVIEW AVENUE
MIRA LOMA, CALIFORNIA 91752
(951) 685-7337 FAX (951) 685-0341
1-800-962-8050
www.hotwalkers.com
E-Mail: centaur@hotwalkers.com

TABLE OF CONTENTS

Unloading the Exerciser	Page 3
Site Preparation	Page 3, 4, 5
Base Installation	Page 3
Head Structure Installation	Page 3
Arm Installation	Page 3, 19
Concrete Pad Installation	Page 6, 7
Electrical Installation Diagram	Page 8, 9, 10, 11, 12
Water & Drain Line Installation	13, 14, 15
Screen Installation	Page 20, 25
Diagram for Electrically Charged Screens	Page 20, 22
Control Box Wiring	16, 17, 18
Turn Buckle Diagram	Page 19, 23, 24
Fence Panel Installation	Page 26, 27, 28
Fenner Transtorque Collar	Page 30
Falk Steel Flex Couplings	Page 31
Nord Drive System	Page 41
Pillow Block Maintenance	Page 37
Operating Instructions	Page 41
Do's & Don'ts	Page 42
Control Box without Timer Operating Instructions	Page 43
Control Box with Timer Operating Instructions	Page 44
Replacement Parts	Page 45
Limited Warranty	Page 46

Grading Diagram

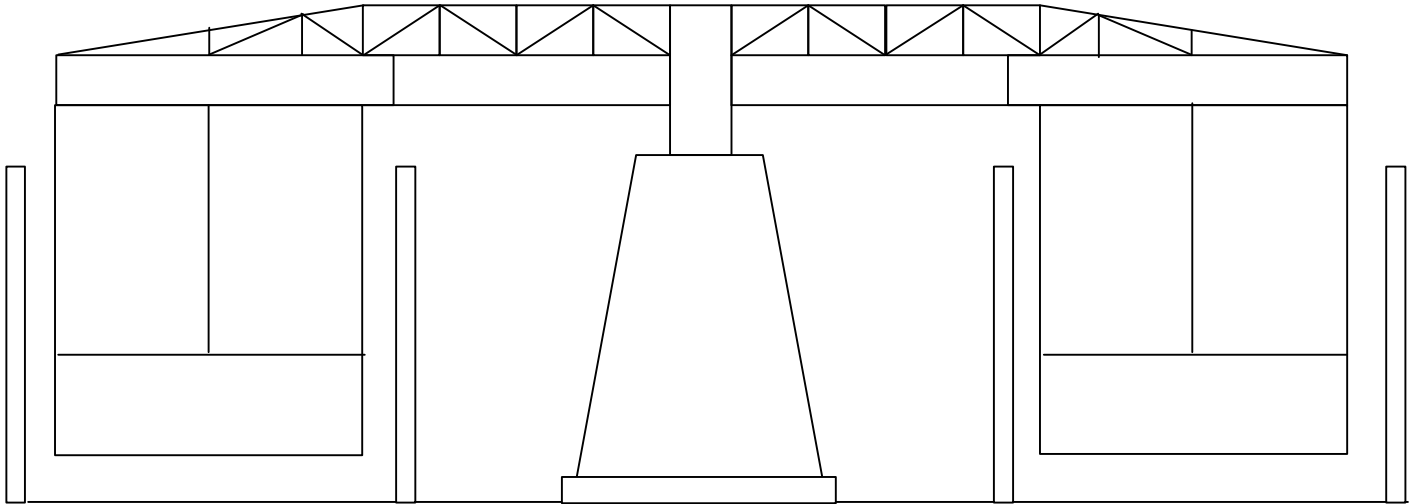

Entire Pad MUST be flat, NO Grade Deviation or Fall (NO 1% GRADE FOR DRAINAGE)

Pad will be 4 ft. larger than the diameter of the Equineciser Model.

**TOP OF THE SLAB MUST BE 5 1/2" ABOVE FINISHED EXERCISING SURFACE
(THE ACTUAL FOOTING/SURFACE HORSES WILL BE EXERCISING ON).**

Apply FINAL exercising surface, AFTER fencing has been INSTALLED.

Please Note: When most Graders and Grading Contractors hear 0% grade, they will grade at 1% to allow for proper drainage. While this is suitable for most buildings, it is NOT suitable for the Centaur Equinecisers. To install the fencing, and the screens properly there must be a true 0% grade. From 4 feet, outside of the diameter desired, and the diameter desired, the ground must be completely FLAT.

Due to numerous installations where the grading and/or the electrical was not done correctly, our Project Coordinator, has had to layover, and incurred more costs than necessary. Now we charge an additional \$1,000.00 to our clients, should our Project Coordinator arrive at the jobsite, and find the pad and/or electrical incorrect. This price is for food, lodging, truck & tool rentals for 2 additional days ONLY, thereafter it is, \$500.00 per day.

The above prices are all based on geographical location of jobsite, the prices could vary upwards. Should you choose one of the optional installation packages offered by Centaur, the above mentioned charges are NOT included in the prices, and will be added to the installation prices if necessary.

ATTENTION:

When most Graders and Grading Contractors hear 0% grade, they will grade at 1% to allow for proper drainage. While this is suitable for most buildings, it is **NOT** suitable for the Centaur Equinecisers. To install the fencing, and the screens properly there must be a **true 0% grade**. From 4 feet, outside of the diameter desired, and the diameter desired, the ground must be completely **FLAT**.

CONCRETE DIAGRAM 1

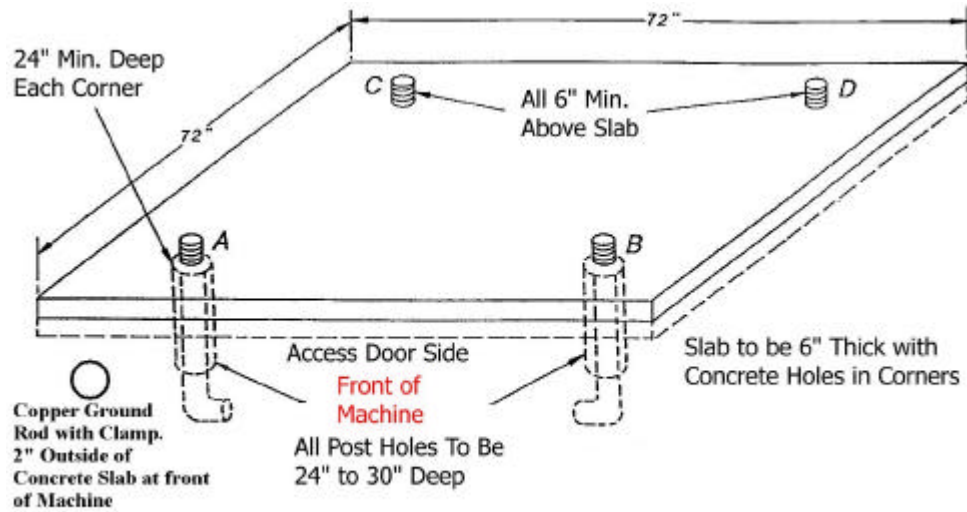

Angular Projection is a visual aid ONLY and is NOT to be scaled.

Electrical Conduits MUST be installed Prior to concrete pour, see Electrical Diagrams for details.

Center Point for Concrete Anchors:

- A to B = 46 1/2"
- C to D = 46 1/2"
- A to C = 57 1/2"
- B to D = 57 1/2"

Diagonals:

- A to D = 74 1/2"
- B to C = 74 1/2"

Anchor Bolts are 3/4" in diameter, and can either be 18" or 24" in length.

NOTE: All Dimensions are from the Bolts NOT the Slab.

Pad should be 72" X 72" (6 ft. X 6 ft.) Square.

CONCRETE DIAGRAM 2

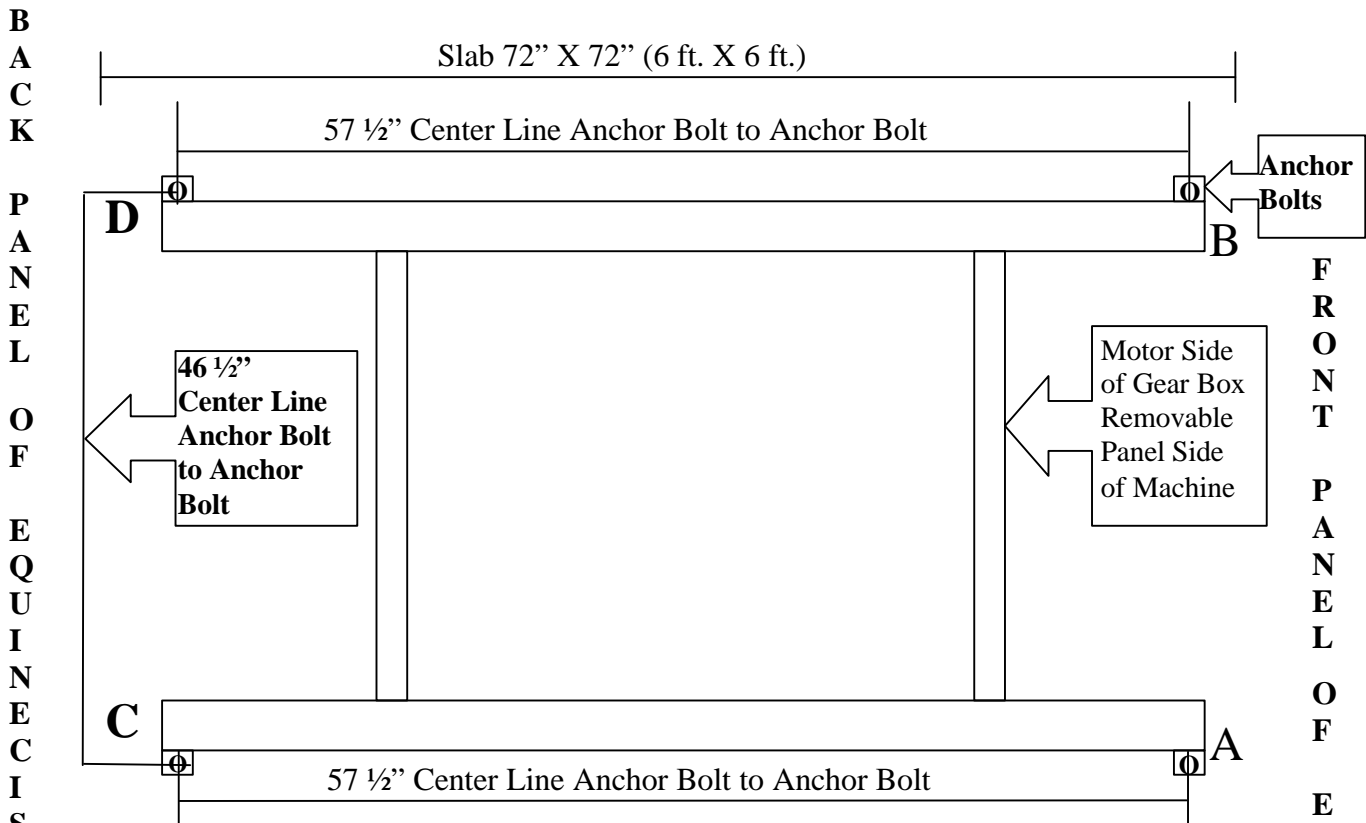

THE ABOVE MEASUREMENTS ARE ACTUAL MACHINE MEASUREMENTS

BACK
PANEL
OF
EQUINE
CISER

FRONT
PANEL
OF
EQUINE
CISER

Center Point for Concrete Anchors:

- A to B = 46 1/2"
- C to D = 46 1/2"
- A to C = 57 1/2"
- B to D = 57 1/2"

Diagonals:

- A to D = 74 1/2"
- B to C = 74 1/2"

Anchor Bolts are 3/4" in diameter, and can either be 18" or 24" in length.

NOTE: All Dimensions are from the Bolts NOT the Slab.

Pad should be 72" X 72" (6 ft. X 6 ft.) Square.

Machine MUST be 5 1/2" above final grade finish grade of horse walking surface Area.

General Electrical Hookup
Overview for Centaur
Free Flow Equinecisers

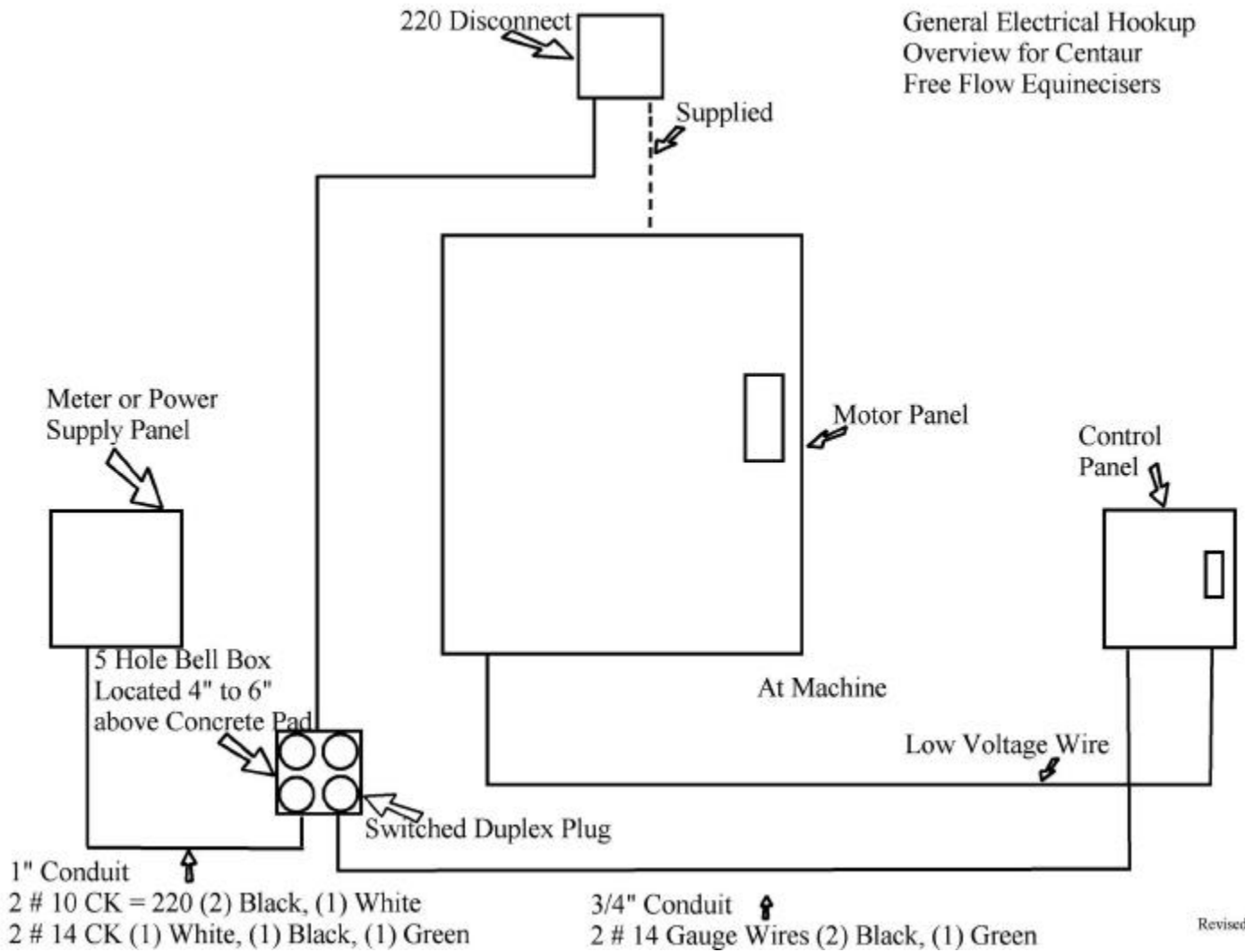

Copper Ground Rod with Clamp MUST BE INSTALLED.
(2" Outside of concrete slab at front of machine.)

ELECTRICAL DIAGRAM 1

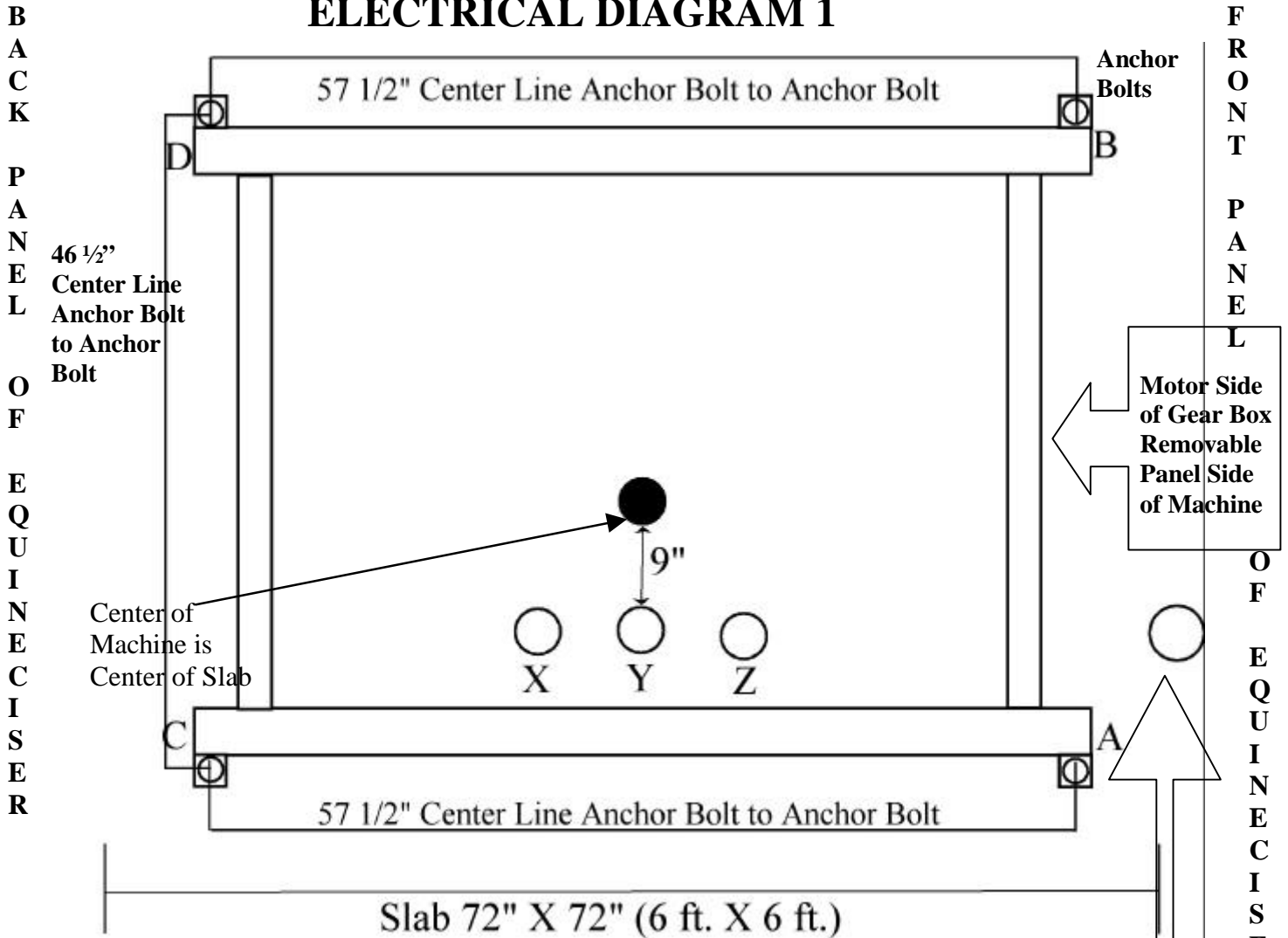

THE ABOVE MEASUREMENTS ARE ACTUAL MACHINE MEASUREMENTS

X = Conduit to Power Supply

20 AMP 220 Volt Circuit and
1 – 15 AMP 110 Volt Circuit,
in **ONE** Conduit. **Both Circuits are to be dedicated**

Y = Conduit to Control Panel

3/4" Conduit with **TWO** Black wires
and **ONE** Green wire.

Z = Conduit to Control Panel

3/4" Conduit for wire loom.

(Wire loom supplied by Centaur)

IF RUN IS LONGER THAN 50 FT. CONTACT CENTAUR CORP.

USE #10 WIRE IF RUN IS UNDER 100 FT. For 220 Volt Power to Equineciser.

Use #12 Wire 110 Volt to Shocker.

IF RUN IS LONGER THAN 100 FT. CONTACT CENTAUR CORP.

**X & Y To be connected into a 2
gang weather proof box**

**Copper Ground
Rod with Clamp
MUST BE
INSTALLED.**
(2" Outside of
concrete slab at
front of machine.)

Centaur Free Flow Equineciser Electrical Diagram 2

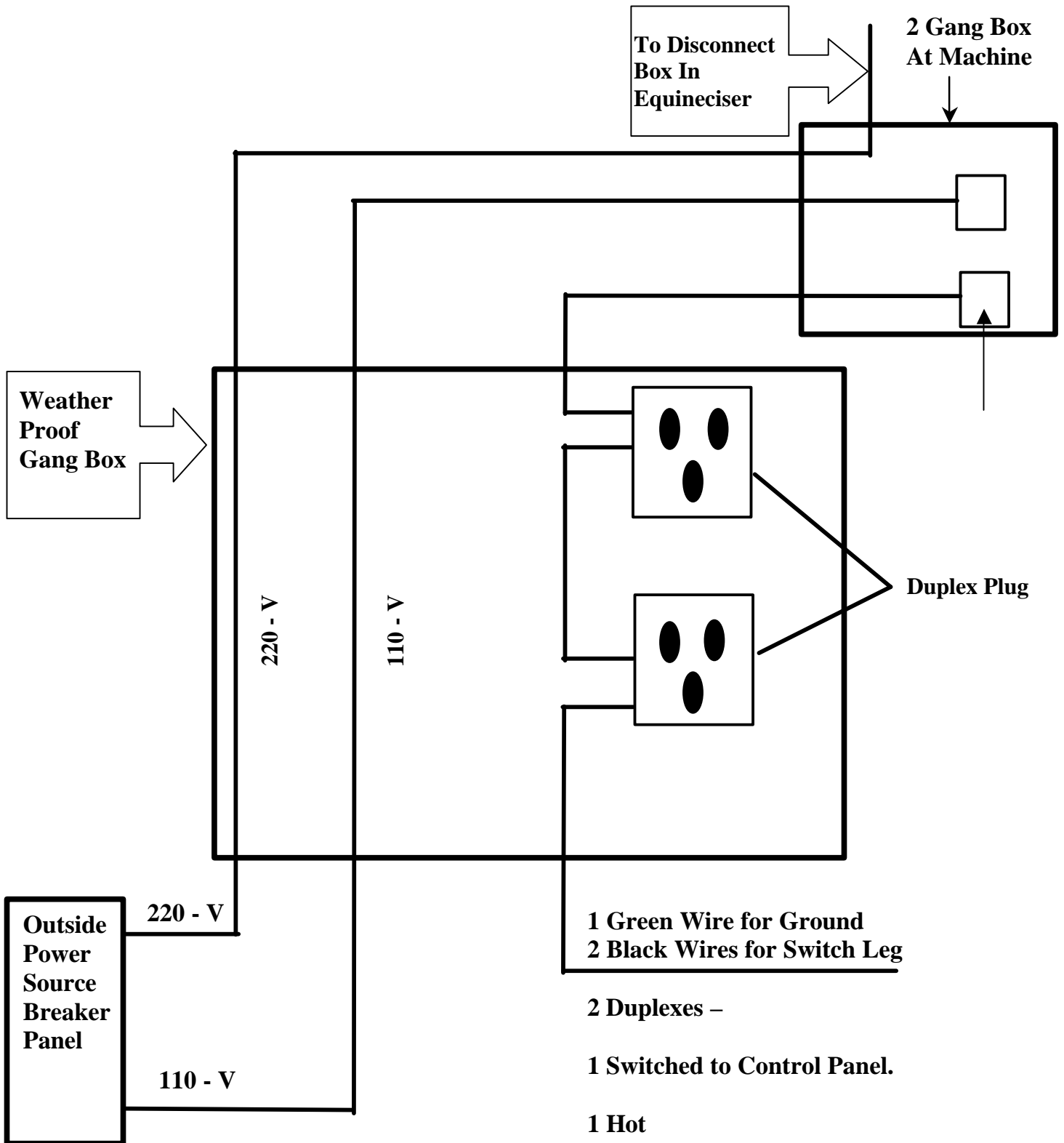

Call our office 1-800-962-8050 with any questions you might have!

Centaur Free Flow Equineciser Electrical Diagram 3

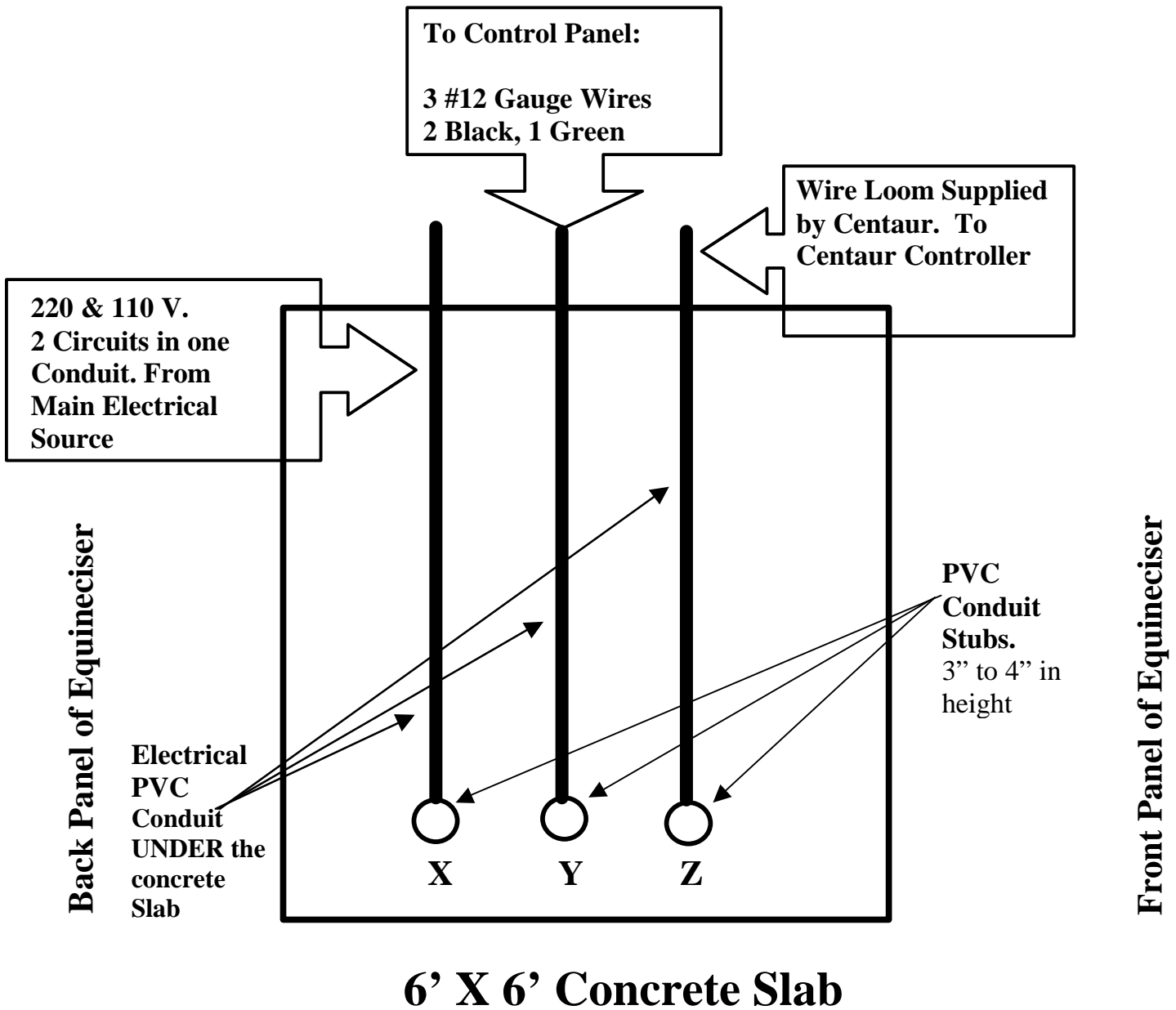

Call our office 1-800-962-8050 with any questions you might have!

X & Y To be connected into a 2 gang weather proof box

Copper Ground Rod with Clamp MUST BE INSTALLED.
(2" Outside of concrete slab at front of machine.)

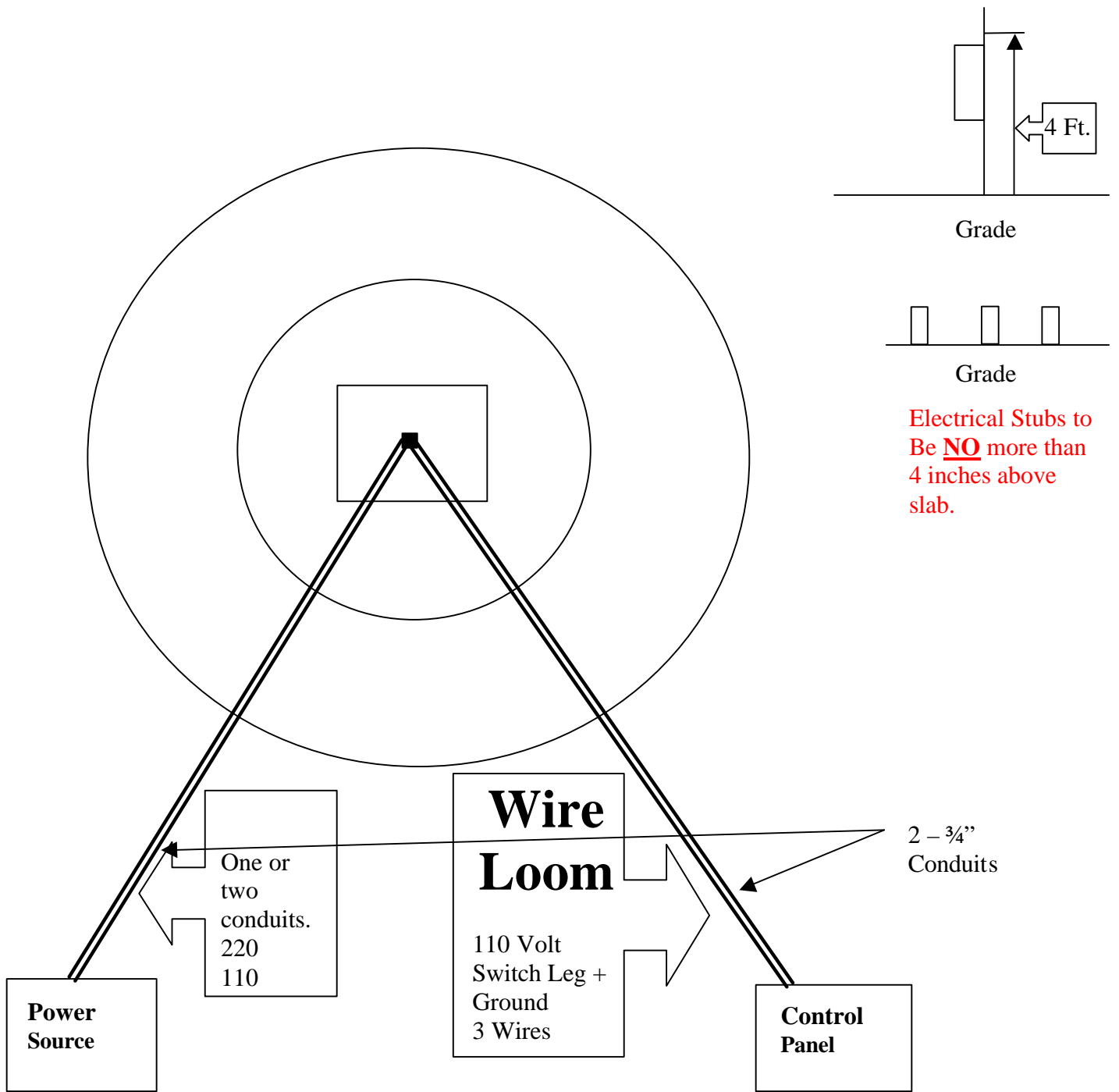

NEED
 110 Circuit to Duplex plug at Equineciser, Switched to Control Panel.

220 to Disconnect at Equineciser.

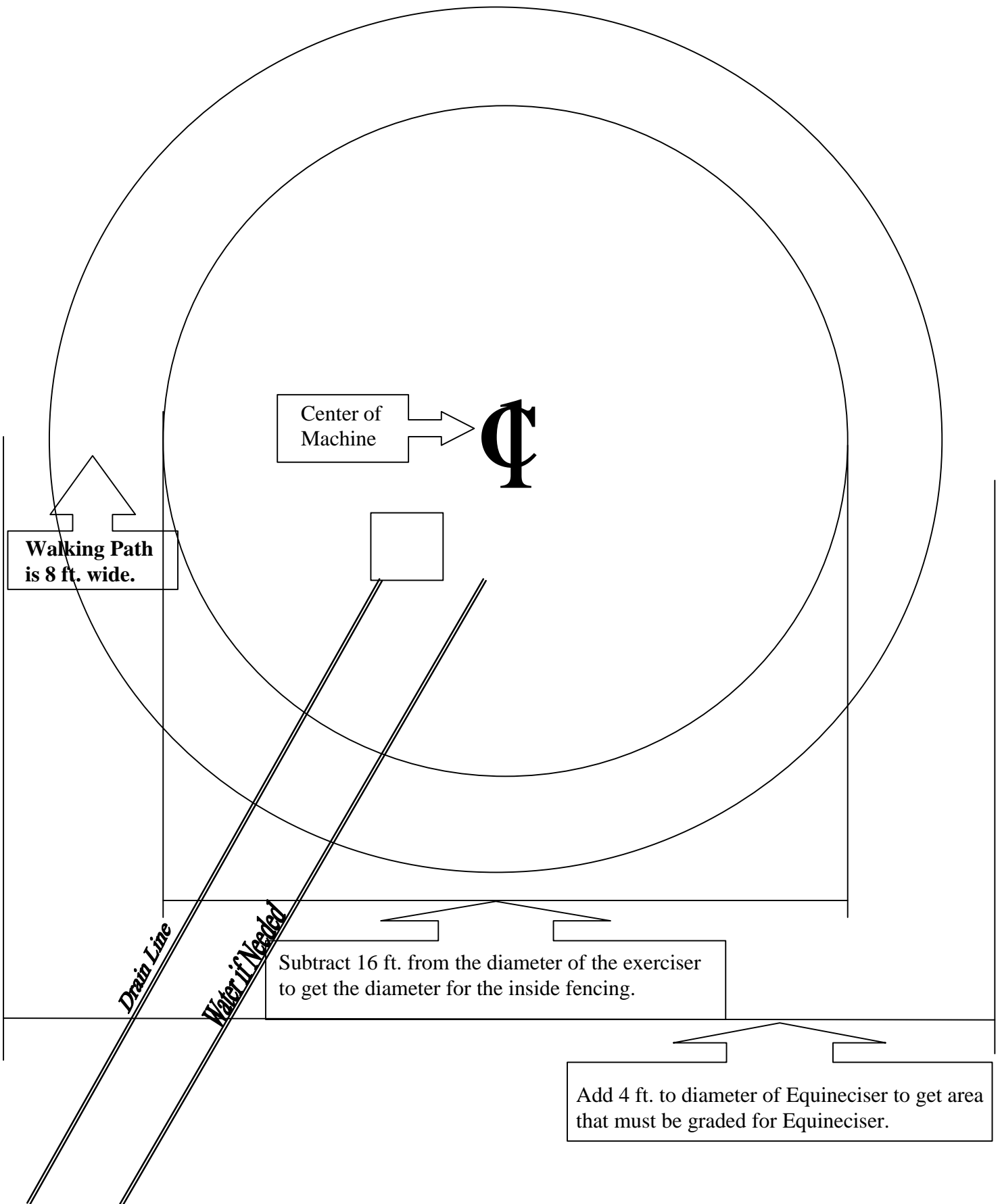

Optional Sprinkler System for Exerciser's Path, for Centaur Free Flow Equineciser

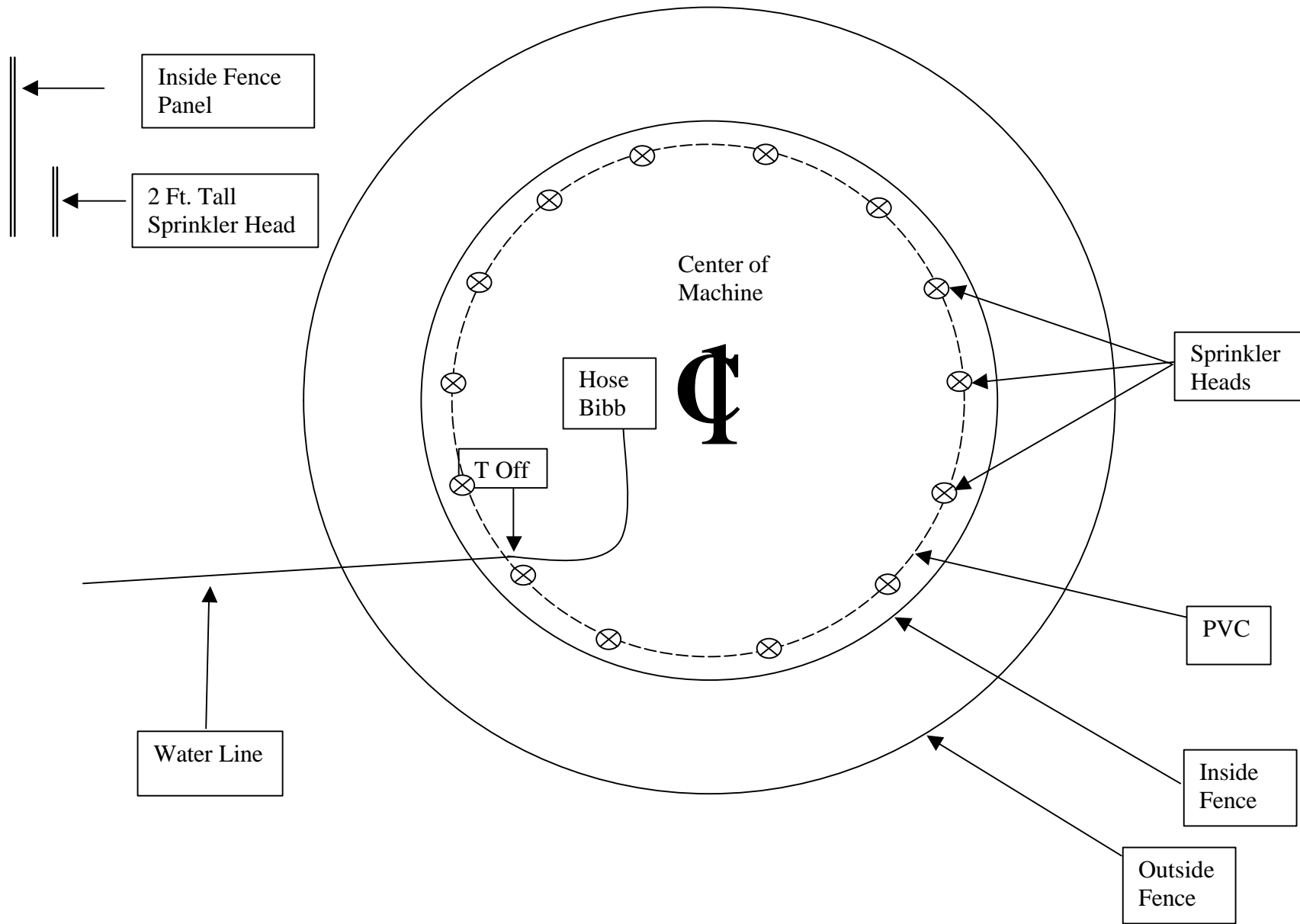

Optional Drain Line for Centaur Free Flow Equineciser

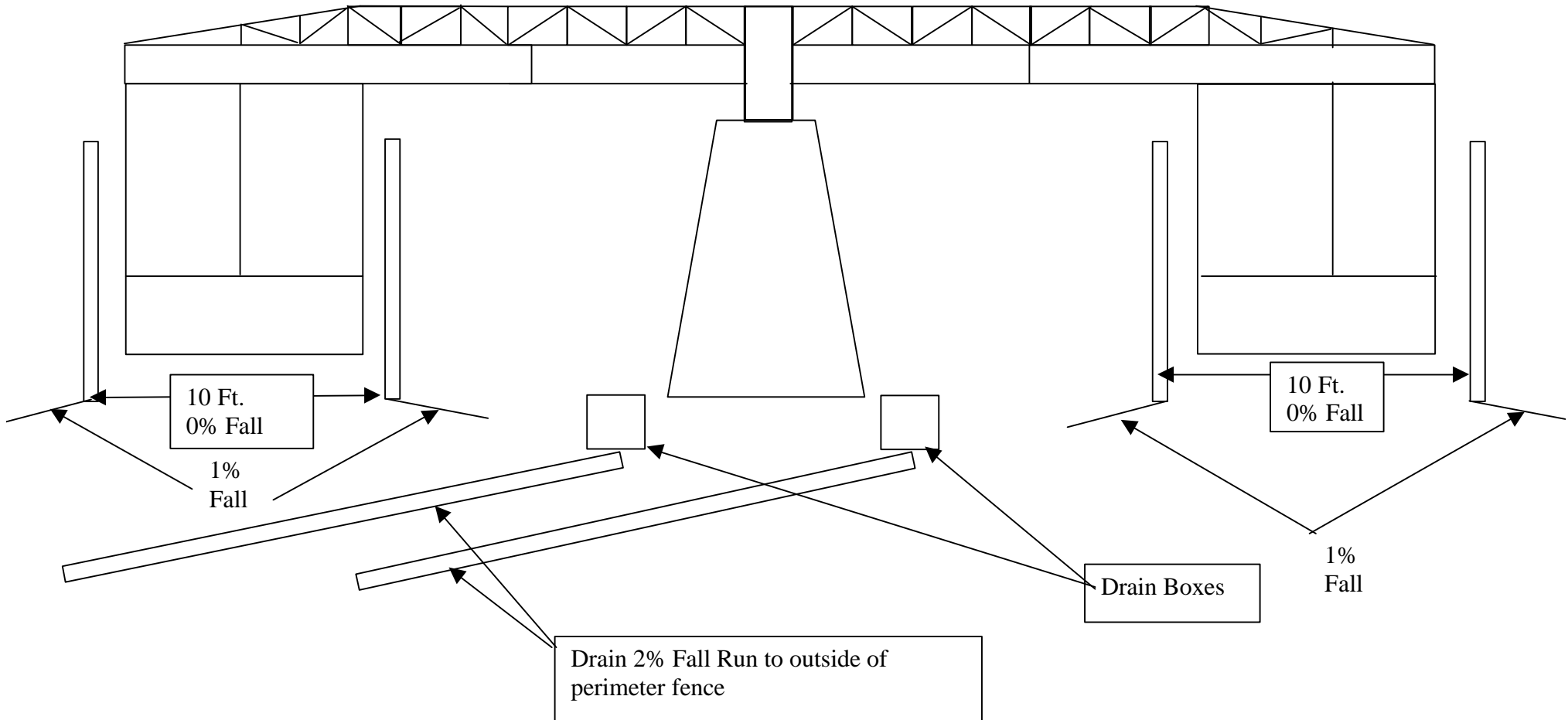

Centaur Equinecisers ABB Control Unit with Timer Wiring Diagram On Backside of Centaur Control Box

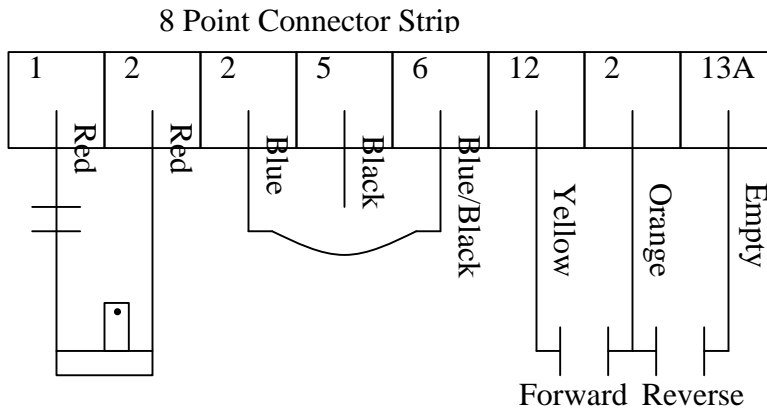

Backside of Centaur Control Box

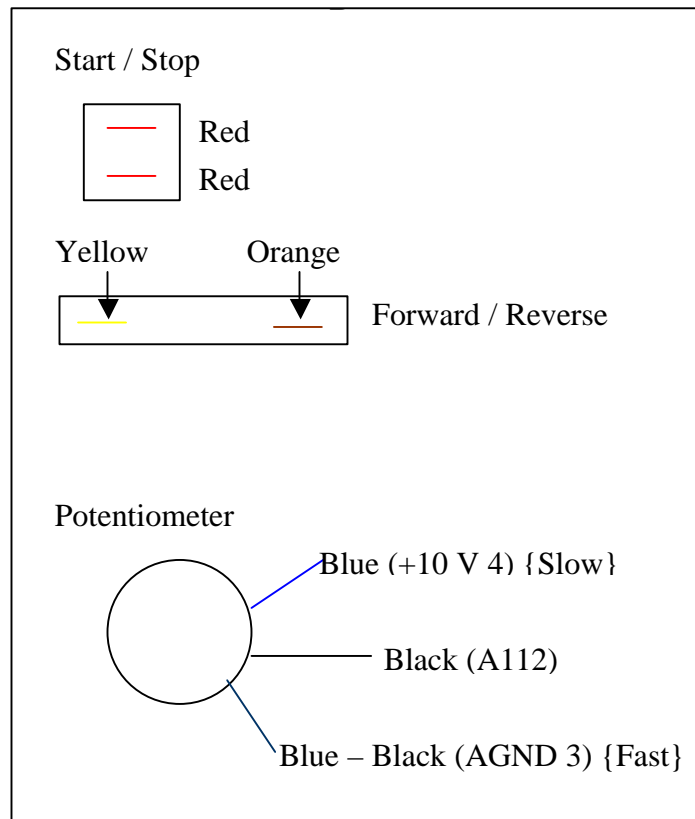

Centaur Equinecisers Control without Timer

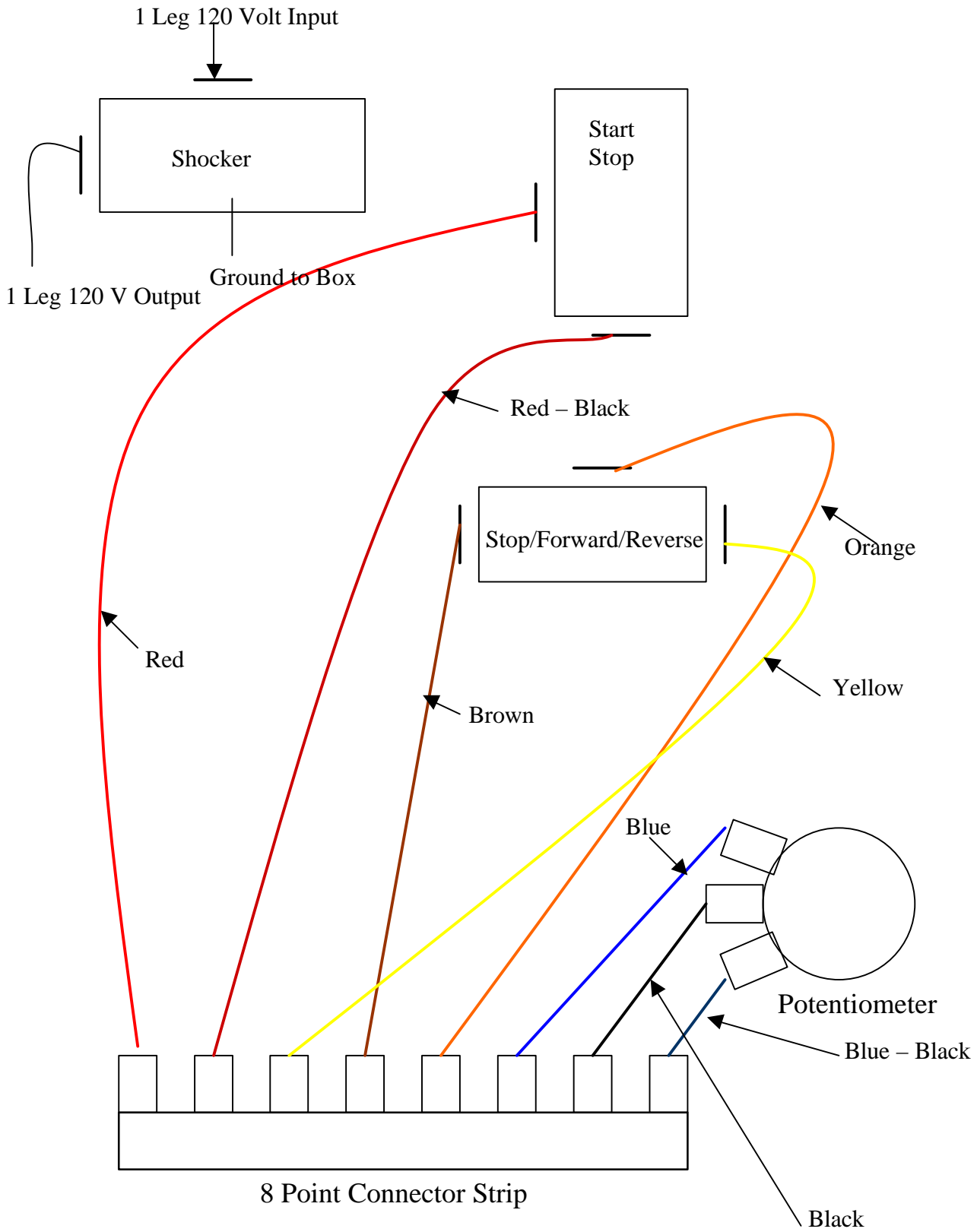

Centaur Equinecisers ABB Controller (Model ACS550) with Timer

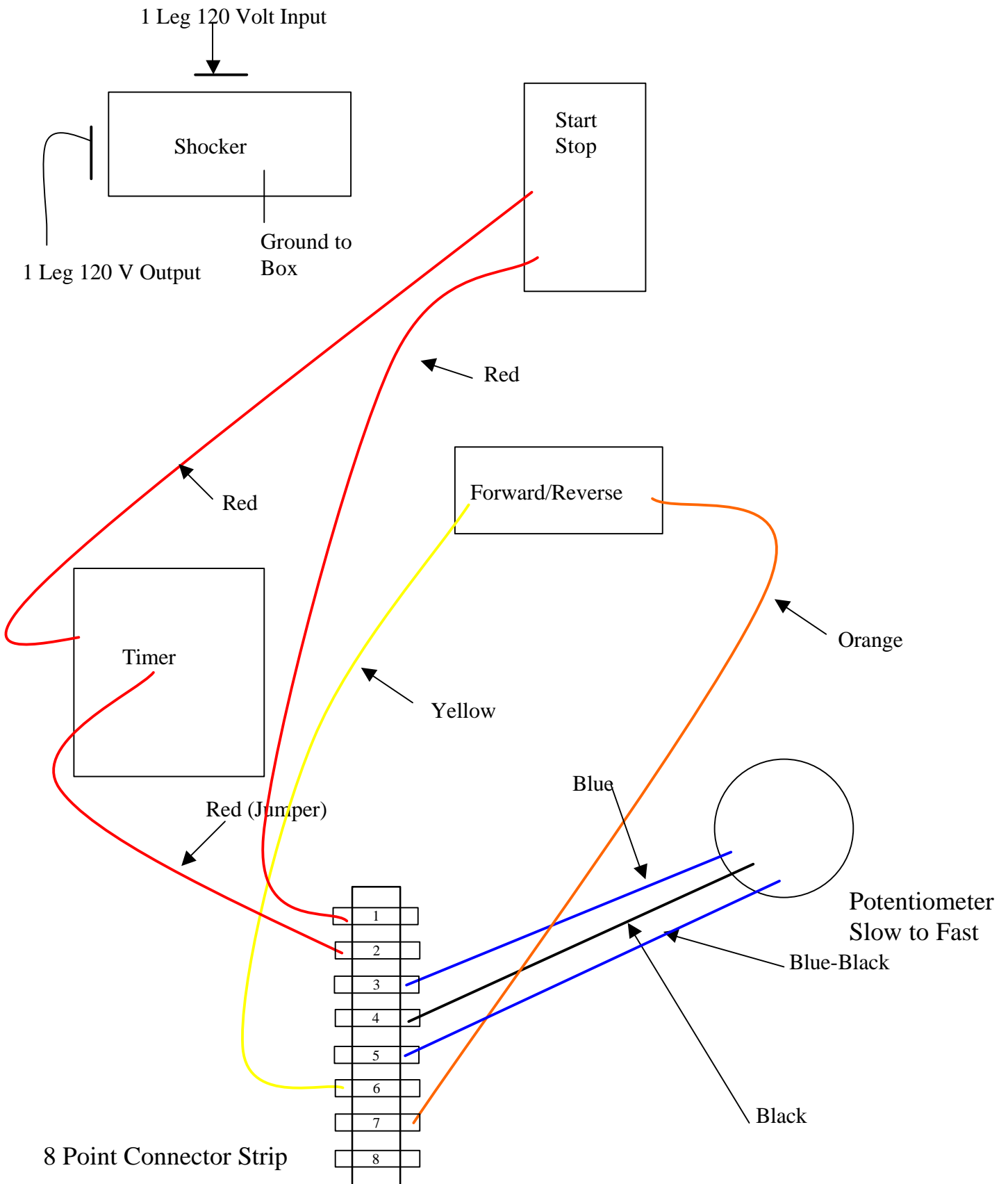

Installation Instructions for Screen Chargers on all Models of Centaur Free Flow Equinecisers

To install the electrical charger system you will find a strand of black wire taped to the vertical shaft inside the Equineciser itself.

There is a large keyway (slot) below the top pillow block bearing, on the vertical steel shaft.

Take the black wire & uncoil it & feed it through the shafts keyway (slot) so the wire comes out above the pillow block bearing & under the large flat steel pan.

You will find a hole $\frac{1}{4}$ in. diameter in the steel pan. Insert the black wire through the hole (from the bottom of the pan) and pull all of the wire through it. So it is under the arm inserts on the round metal shaft, and is resting on the flat steel pan.

At the far end of each small arm by the screen end you will find a hole in the $2\frac{1}{2}$ " X $2\frac{1}{2}$ " steel arm, using an electricians snake, slide it through the hole all the way back through the 3" X 3" main support arm.

You will find a hole also in the 3" X 3" using a wire hook grab the electrical snake & pull it through the hole in the 3" X 3" arm.

There were individual black wires sent to you, 1 for each arm.

Attach the 1 piece of black wire to the snake & pull it through the arm. Pull slowly so not to rip insulation from special wire.

Leave about 3 ft. + by head assembly & allow the rest of the wire to pass out of the $2\frac{1}{2}$ " X $2\frac{1}{2}$ " arm hole. The arm hole will be on the bottom of the arm

There were also some pieces of clear plastic tubing 1' each sent to you, (it takes 2 – 1 ft. pieces of clear plastic tubing for each arm, one for the 3" X 3" hole & one for the $2\frac{1}{2}$ " X $2\frac{1}{2}$ " hole.

Take each of the 1 ft. clear plastic tubes & slide it over the black wire where it enters the 3" X 3" & $2\frac{1}{2}$ " X $2\frac{1}{2}$ " arms. The plastic keeps the black wire from rubbing against the steel arm and shorting out.

On top of each screen frame that hangs from the arm with chain, place 1 – lug receiver 6" in from inside of frame – Use a self-drilling tek screw to anchor the lug.

Strip back the black wire & prior to attachment wrap the black wire around a large screwdriver shaft, to make a tight coil – similar to your phone cord. This will allow you to raise or lower the screen chains without tearing the wire loose from the lug connections.

Now go back & take each of the arm wires by the tower head assembly & tie them all together with the one wire that came up through the key slot on the vertical shaft.

Use 1 large wire nut to tie them all together then wrap with electricians splicing tape tightly. Then wrap again with regular electrical tape the wires simply lay on top of the large round steel pan near the central vertical shaft.

See other drawings on how to connect shocker wires from controller to the charge box, (the charge box is mounted on inside wall of the Equineciser). Also refer to the standard concrete & electrical installation information that was also sent to you.

To test if screens are charged: Take a piece of wire and wrap around the ground wire and with the other end of the wire stripped back, touch the screen frame or welded wire on screen you should see a pulsating spark or snap if all connections are grounded & connected properly.

NOTE: Moving Screen **CANNOT** touch the Centaur Standard Steel Fence Panels when in place or moving.

If the screens rub or touch they will short out the charger box.

Arm Assembly

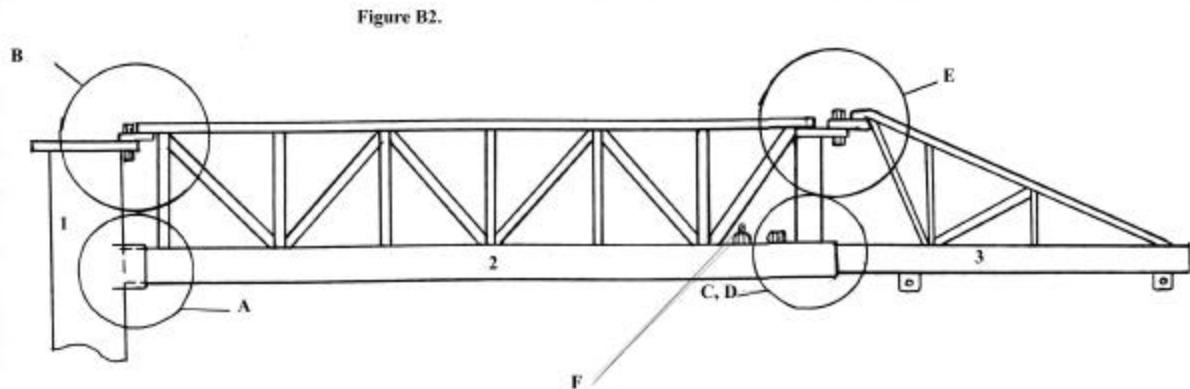

1. Top of Free Flow Exerciser
2. Primary Arm Truss
3. Secondary Arm Truss

- A. Slide Primary Arm Truss into receiving box on head.
- B. Fasten Tabs with Nut & Bolt Assembly.
- C, D. Slide Secondary Arm Truss in receiving end of Primary Arm Truss. Fasten Primary Arm to Secondary Arm with lock Bolt & Nut Assembly.
- E. Fasten Tabs with Nut & Bolt Assembly.
- F. Nut & Bolt that Cable fastens to.

IMPORTANT: (See Figures C or C2) You will notice on the super structure there is another bolt that is threaded it lies right behind the first bolt where you inserted the smaller arm. The secondary bolt is where you take your cable pieces, make a small loop on the end of it with a cable clamp and a small loop on the other end with a cable clamp, and you apply them around these additional nuts & bolts you will do 4 of them that way, looking at the diagram that I have included for you on placement of the turnbuckles. There are 2 turn buckles on the inside of the cable that will go opposite each other on 2 of the 6, shorter cables, (length based on model). By rotating the turnbuckles you will apply tension on all the other cables. **IMPORTANT:** make sure the cable clamp nuts are on tight so cable will not slip out.

SCREEN INSTALLATION:

(See Figure D) You will find 2 hangers per each screen, the hangers are pieces of flat steel 2 ½” wide 3/8” thick with 1” hole on center.

On each arm you will find 2 plates welded to the end and 7’6” from the end with a 1” hole in each. Take 1 Quick Link and place in each opening. Now add 1 – 1’ piece of ¼” chain to each link.

Now each screen has a tab on each side with a 1” hole. Place 1 Quick Link in each hole. Now attach the screen to each piece of chain. Adjust if necessary to make screen hang level. Take 1 – 2 ft. pieces of chain and attach it to the tab on the bottom of the 3” X 3” big arms with quick link on each end. Used to pull screen off center, so that screen does not hit outside fence.

NOTE: The Rubber Mats should be drilled & cut to your desired length. The drill size is 3/8” and there are 6 holes to hand the mat to at the bottom of each screen. They take 6 bolts, 12 washers, & 6 nylock nuts.

Installation Instructions for Screen Chargers on all Models of Centaur Free Flow Equinecisers

To install the electrical charger system you will find a strand of black wire taped to the vertical shaft inside the Equineciser itself.

There is a large keyway (slot) below the top pillow block bearing, on the vertical steel shaft.

Take the black wire & uncoil it & feed it through the shafts keyway (slot) so the wire comes out above the pillow block bearing & under the large flat steel pan.

You will find a hole ¼ in. diameter in the steel pan. Insert the black wire through the hole (from the bottom of the pan) and pull all of the wire through it. So it is under the arm inserts on the round metal shaft, and is resting on the flat steel pan.

At the far end of each small arm by the screen end you will find a hole in the 2 ½” X 2 ½” steel arm, using an electricians snake, slide it through the hole all the way back through the 3” X 3” main support arm.

You will find a hole also in the 3” X 3” using a wire hook grab the electrical snake & pull it through the hole in the 3” X 3” arm.

There were individual black wires sent to you, 1 for each arm.

Attach the 1 piece of black wire to the snake & pull it through the arm. Pull slowly so not to rip insulation from special wire.

Leave about 3 ft. + by head assembly & allow the rest of the wire to pass out of the 2 ½” X 2 ½” arm hole. The arm hole will be either on the top or on the bottom of the arm

There were also some pieces of clear plastic tubing 1’ each sent to you, (it takes 2 – 1 ft. pieces of clear plastic tubing for each arm, one for the 3” X 3” hole & one for the 2 ½” X 2 ½” hole.

Take each of the 1 ft. clear plastic tubes & slide it over the black wire where it enters the 3” X 3” & 2 ½” X 2 ½” arms. The plastic keeps the black wire from shorting out.

On top of each screen frame that hangs from the arm with chain, place 1 – lug receiver 6” in from inside of frame – Use a self-drilling tek screw to anchor the lug.

Strip back the black wire & prior to attachment wrap the black wire around a large screwdriver shaft, to make a tight coil – similar to your phone cord. This will allow you to raise or lower the screen chains without tearing the wire loose from the lug connections.

Now go back & take each of the arm wires by the tower head assembly & tie them all together with the one wire that came up through the keyslot on the vertical shaft.

Use 1 large wire nut to tie them all together then wrap with electricians splicing tape tightly. Then wrap again with regular electrical tape the wires simply lay on top of the large round steel pan near the central vertical shaft.

See other drawings on how to connect shocker wires from controller to the charge box, (the charge box is mounted on inside wall of the Equineciser). Also refer to the standard concrete & electrical installation information that was also sent to you.

To test if screens are charged: Take a piece of wire and wrap around the ground wire and with the other end of the wire stripped back, touch the screen frame or welded wire on screen you should see a pulsating spark or snap if all connections are grounded & connected properly.

NOTE: Moving Screen **CANNOT** touch the Centaur Standard Steel Fence Panels when in place or moving.

If the screens rub or touch they will short out the charger box.

DIAGRAM FOR ELECTRICALLY CHARGED SCREENS ONLY

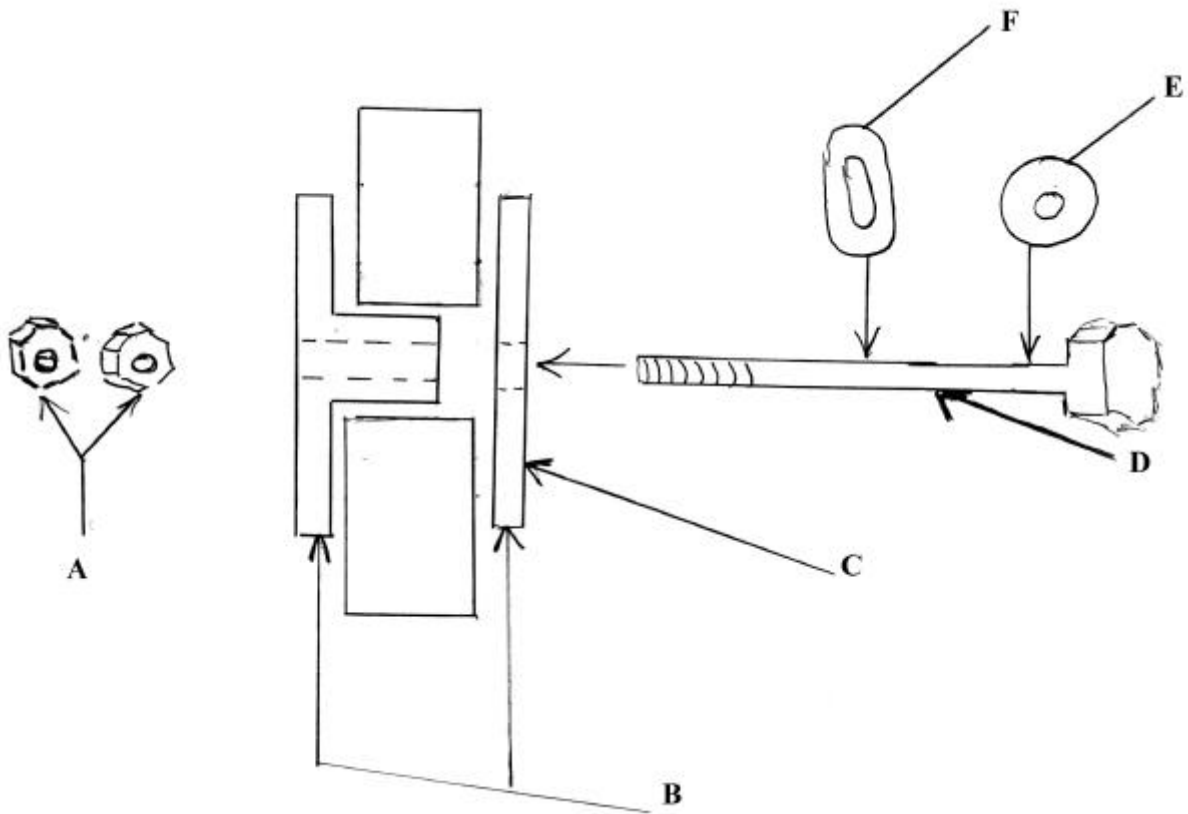

- A. 2 – 3/16” Nuts
- B. Plastic Insert & Plastic Washer
- C. Top view of 1” hole in top of screen hanger
- D. 2 ½” X 3/16” Bolt
- E. 3/16” Washer
- F. 1st Link of chain in 1ft piece.

Turn Buckle Diagram

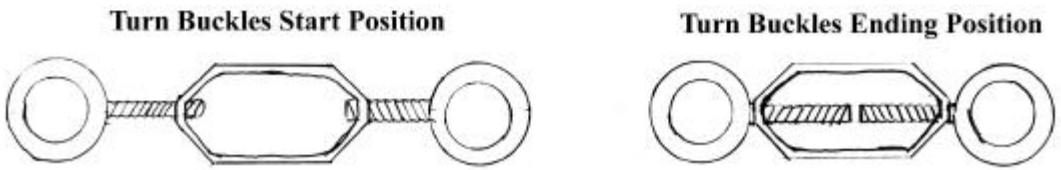
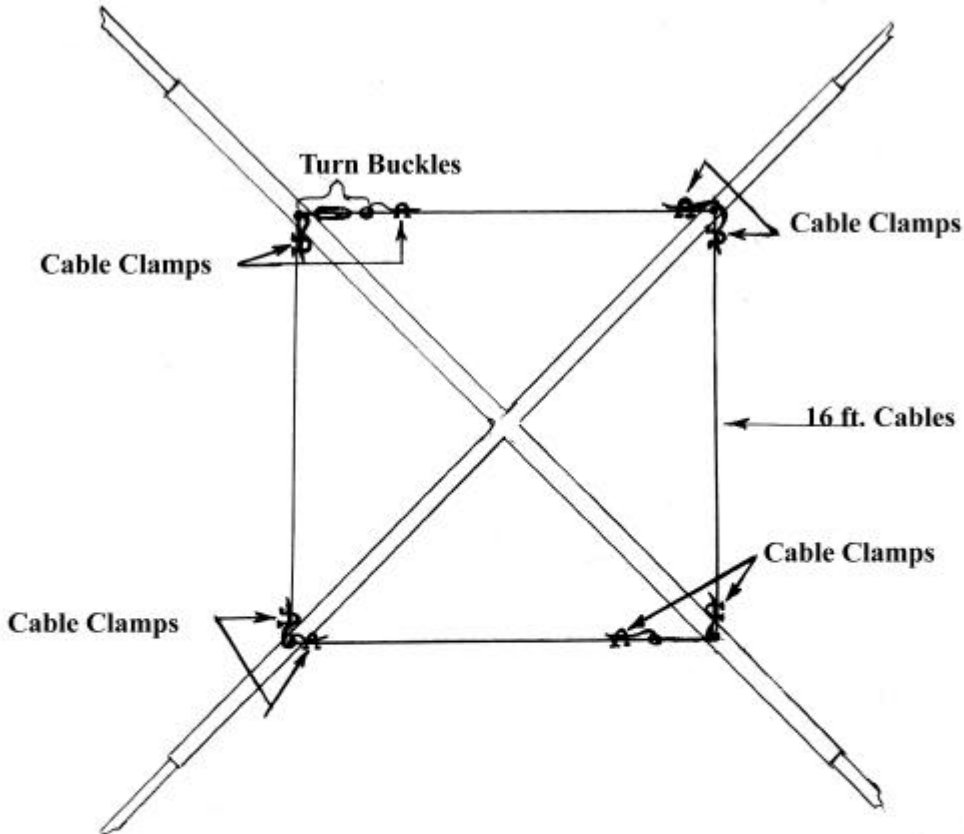

Cable Clamps & Turn Buckle Installation Figure C.

TURN BUCKLE DIAGRAM

Figure C2.

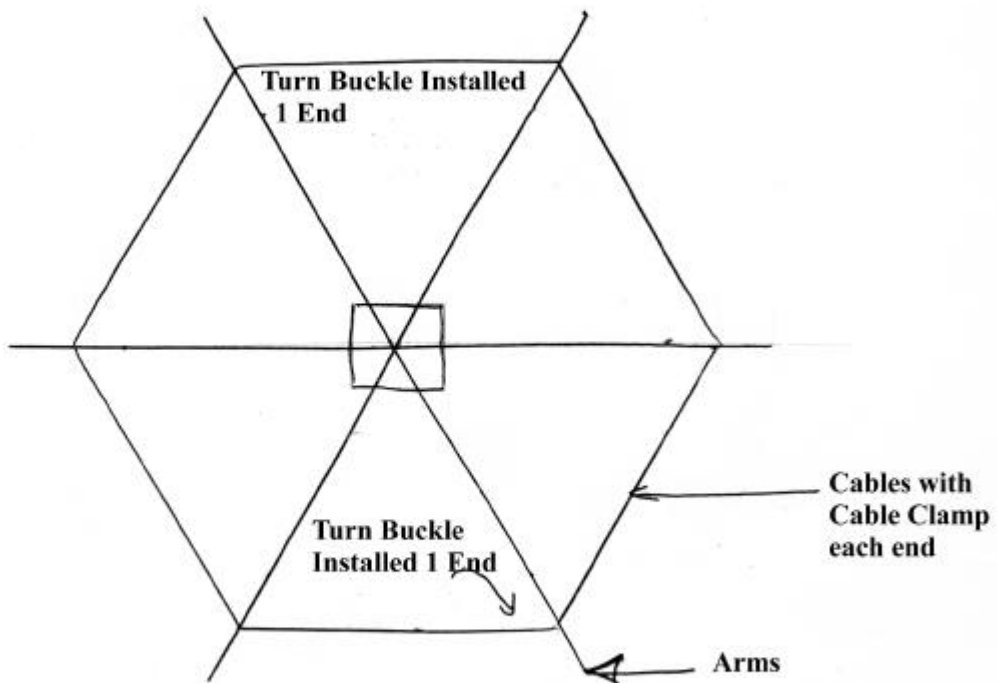

Screen Installation Figure D.

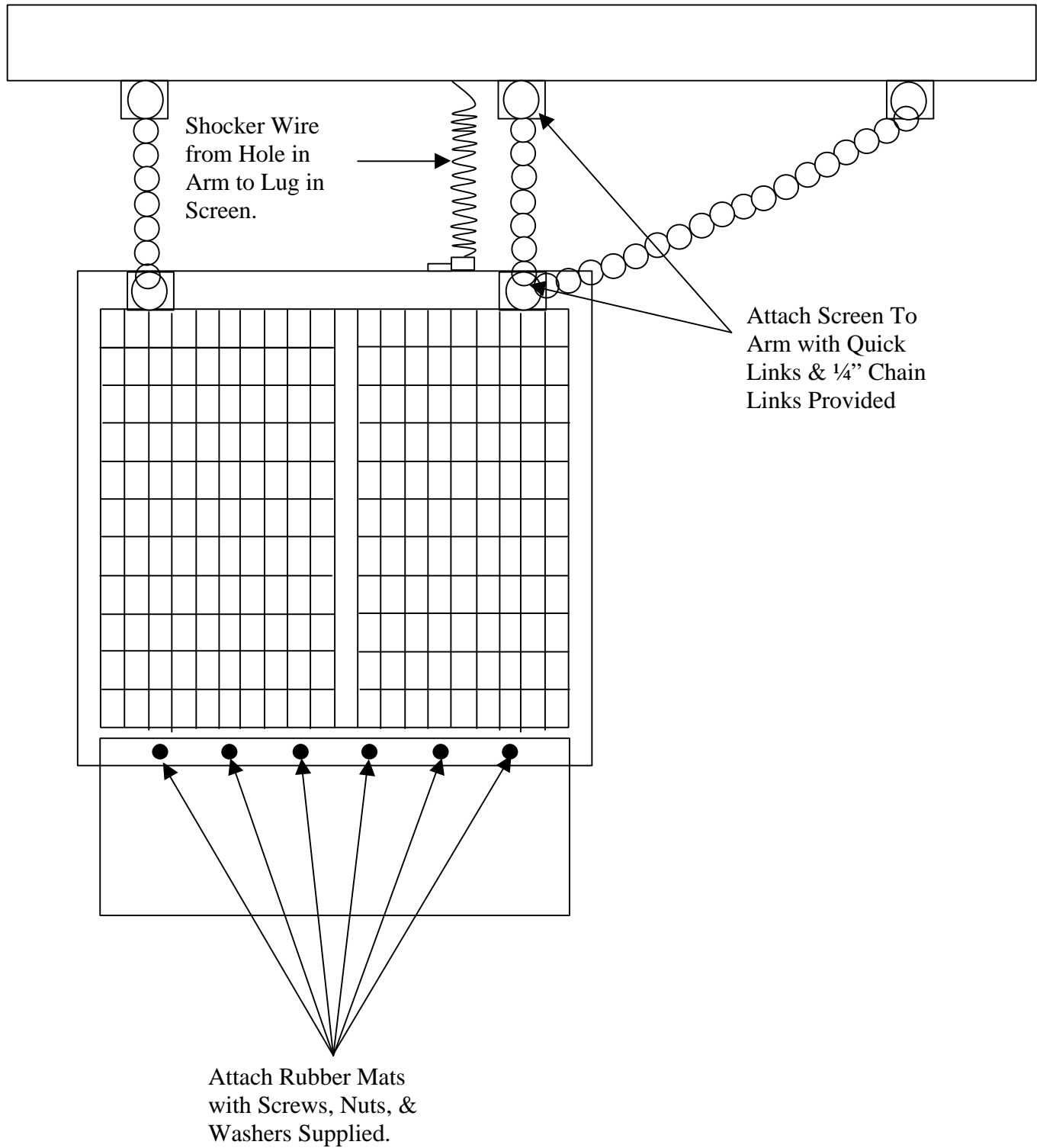

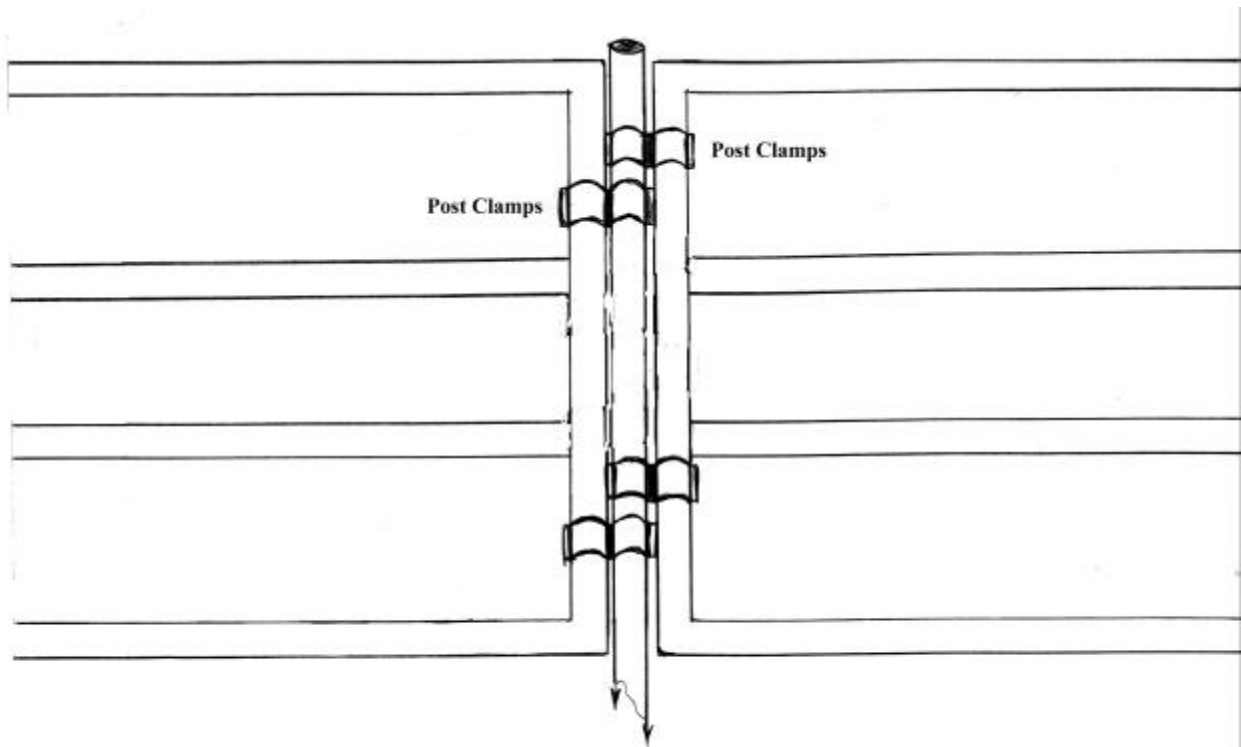

Fence Assembly Figure E.

POSTS ARE OPTIONAL. THEY ARE NOT REQUIRED FOR FENCING.

FENCE PANEL DIAGRAM

Figure E2.

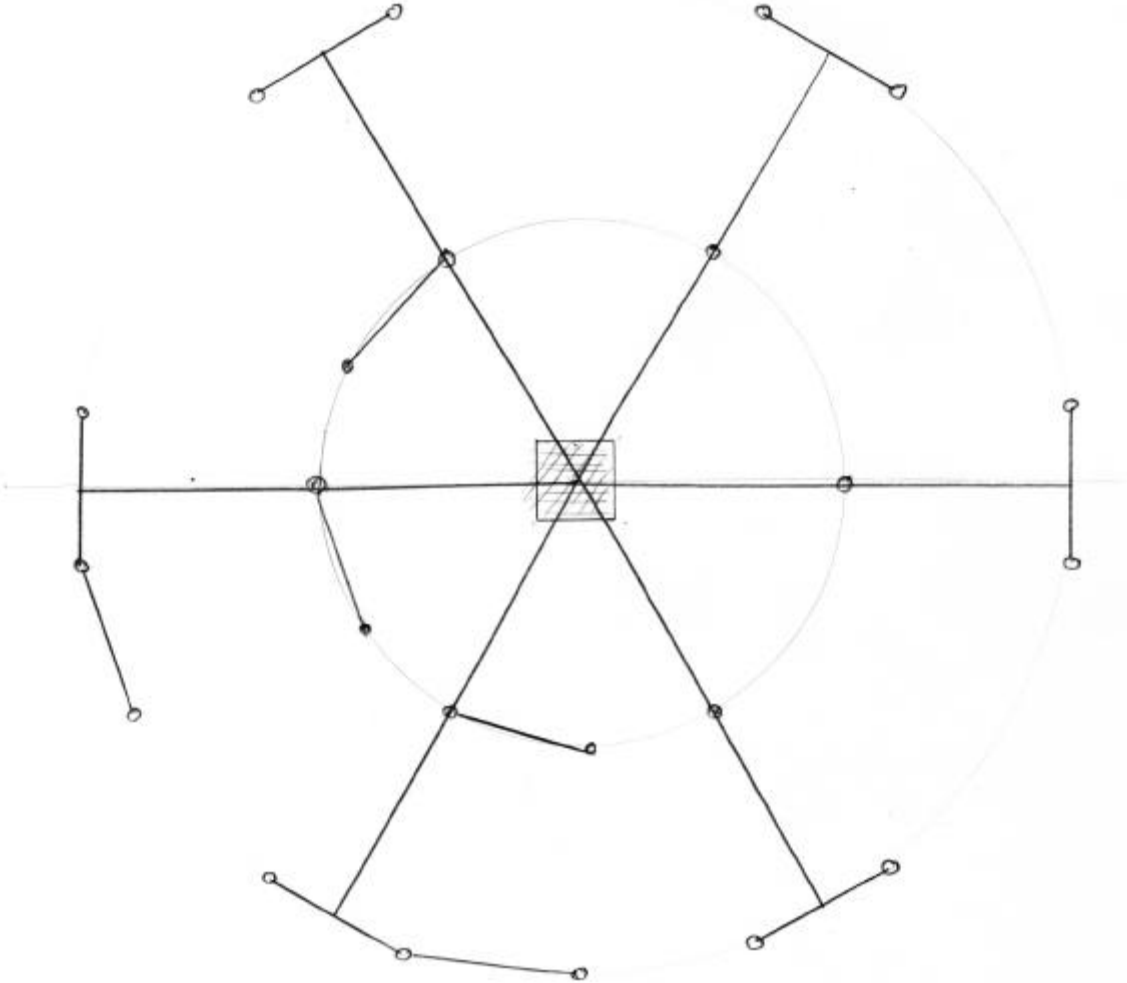

NOTE: Outside Panels 90 degrees to arm end. Inside Panels are offset/post is under arm.

FENCE INSTALLATION (If you purchase it from us)

(See Figures E & E2) At the end of one arm with the screen & mat hanging on it, you will take an 8' long, 7' tall welded wire panel, (they are designed so you can have the welded wire on the inside by the horse or you can have the welded wire on the outside away from the horse, it's entirely up to you it's a subjective call). The fence panels are 8ft in length put a mark at 4 ft in (half way on the length) place the first panel so that you have 4 ft to the left and 4 ft to the right of the arm. If you are looking down it will look like the letter T. You want to divide the 8ft panel exactly in half perpendicular to the arm. **POSTS ARE OPTIONAL.** You have 10, 8 - foot posts, they go on the outside of your first 8 foot fence panel it will take 4 clamps on the left side and 4 clamps on the right side, the clamps attach to the post on each side, the next panel sets in the same manner. We have found that in the past that if you take a panel and place the panel at the end of each arm centered you can then fill in the area, quickly. What you will want to do, lay the 8 ft panels down, laying outward or away from the end of the arm so as you raise them, the panels will fall just to the outside of each arm we've allowed only a few inches of clearance. I do not recommend you start placing posts in the ground until you have the entire exterior panels wiggled around and in proper placement. Put a gate panel at end of each arm 5 sets will be 1 gate, 3 panels, 1 gate, 3 panels, the last set will be 1 gate panel & 2 fence panels. I also suggest that you bring all your 7 ft tall, 7 ft long panels and your one 7 ft tall, 7 ft long gate panel, along with your 20 – 10 ft posts, (you have 23 – 10 ft posts for the outside panels), posts to the inside area by the exerciser so you are not struggling with them to bring them in once you have installed your outside fencing.

Once you have completed your outside fencing, move to the inside & install your interior 7 ft tall fence system. **NOTE** That this fence will stay clear of the inside panel. On the inside panel fencing you put a post under the arm & attach the panels on either side, see diagram (the outside panels offset the inside panels).

After the fences are up you can then begin to pound the posts into the soil or concrete them in the ground.

Finally install the rest of your arm screens & mats.

MAINTENANCE & LUBRICATION SCHEDULE

NOTE: Remove the entire cover for easy service, which is made up of 4 individual panels.

Fenner Transtorque tightening collar see page 28

Falk Steelflex Couplings see page 29 – 34

Nord Drive System see page 35 – 38

2 Pillow Block units on vertical shaft see page 39

FENNER TRANTORQUE TIGHTENING COLLAR:

A Trantorque GT Keyless Bushing offers flexible and easy installation while providing exceptional holding power. To ensure a Trantorque GT unit performs as specified, it must be installed properly.

Warning: Use no lubricants in this installation.

1. Shaft and component bore must be within ± 0.003 " (± 0.0015 " mini series) of stated bore diameter and must have a surface finish of 32-125 Ra (roughness average). If the surface finish is outside these specified values, consult Fenner Drives.
2. Both shaft and component bore must be completely free of paint, grease, oil, and dirt. If necessary, clean the surfaces with a non-petroleum based solvent, such as isopropyl alcohol.

Warning: Do not lubricate the Trantorque GT bushing or shaft. The use of any lubricant on the contact surfaces could result in bushing failure and will void all warranties.

Installation Torque on Nut				
	Inch Pound System		Metric System	
	Shaft Size	In. Lbs.	Shaft size	N-m
MINI SERIES	3/16-1/4	125	5-6mm	14.1
	5/16-3/8	150	7-9mm	17.0
	7/16-1/2	175	10-12mm	19.8
	9/16-5/8	200	14-16mm	22.6
	3/4	700	17mm	80.0
STANDARD SERIES	5/8-3/4	1200	15-19mm	136
	13/16-1	1500	20-25mm	170
	1-1/16-1-1/4	2000	28-32mm	225
	1-5/16-1-1/2	2300	34-38mm	260
	1-9/16-1-3/4	2800	40-42mm	316
	1-13/16-2	4900	45-50mm	554
LARGE SERIES	2-1/16-2-1/4	5300	55mm	600
	2-5/16-2-1/2	5600	60mm	635
	2-9/16-2-3/4	6000	65-70mm	680
	2-13/16-3	6600	75mm	750

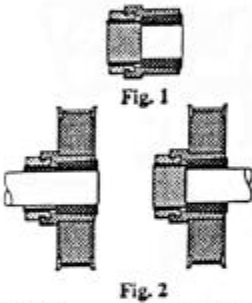

3. Insert the Trantorque GT unit into the component to be mounted, making sure the mating hub is flush against the shoulder at the hex flats.

4. Position the assembly at the desired location on the shaft and hand-tighten the nut (clockwise) until the assembly becomes snug on the shaft.

Warning: Do not hammer or use any type of impact to force the Trantorque GT assembly along the shaft.

Warning: The shaft must fully engage the shaft gripping area (Figure 1) of the Trantorque GT unit. Figure 2 illustrates minimum shaft engagement.

5. Using a torque wrench, tighten the nut to the proper installation torque. See table for torque value. (Note: Fenner Drives has available crowfoot wrenches for square drives in sizes from 1/2" to 3-1/2".) The hex flats on the outer ring are provided for counter-torque, eliminating the need to hold the component or shaft while applying installation torque.

Note: At full installation torque, the assembly will have moved approximately 1/16" axially along the shaft away from the nut. If axial position is critical it may be necessary to loosen the nut and reposition the assembly.

Warning: Over-tightening the nut could damage the Trantorque GT unit and/or the mounted component.

Printed in U.S.A.



Phone: (717) 665-2421

Fax: (717) 665-2649

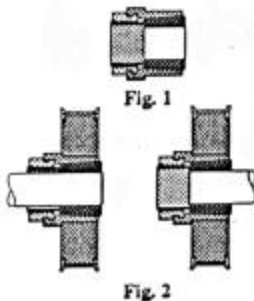

3. Inserte el Trantorque GT en la componente para ser montado, asegurandose que el componente este dividamente montado sobre la superficie y pegada a la contratuerca.

4. Posicione el ensamblaje en el lugar deseado de la flecha y apriete la tuerca del trantorque con la mano, en direcci3n a las manecillas del reloj, hasta que el ensamblaje se una completamente con la flecha.

Precauci3n: No utilice martillo 3 cualquier tipo de impacto para forzar el ensamblaje del Trantorque GT con la flecha.

Precauci3n: La flecha debe de embonar completamente en el Trantorque GT. (Figura 1) Figura 2 muestra como uno m3nimo de embone de la flecha en el Trantorque GT.

How To Use This Manual

This manual provides detailed instructions on maintenance, lubrication, installation, and parts identification. Use the table of contents below to locate required information.

Table of Contents

Introduction	Page 1
Lube Fittings	Page 1
Limited End Float	Page 1
Lubrication	Pages 1-2
Installation & Alignment Instructions	Pages 2-4
Annual Maintenance, Relube & Disassembly	Page 4
Installation & Alignment Data	Page 5
Parts Identification & Parts Interchangeability	Page 6

CAREFULLY FOLLOW THE INSTRUCTIONS IN THIS MANUAL FOR OPTIMUM PERFORMANCE AND TROUBLE FREE SERVICE.

INTRODUCTION

This manual applies to Sizes 1020T thru 1140T and 20T thru 140T10 Falk Steelflex Tapered Grid Couplings. Unless otherwise stated, information for Sizes 1020T thru 1140T applies to Sizes 20T thru 140T respectively, e.g. 1020T = 20T, 1100T = 100T, etc. These couplings are designed to operate in either the horizontal or vertical position without modification. Beginning in 1994, these couplings are being supplied with one set of inch series fasteners and one set of metric fasteners. Use either set of fasteners, depending on your preference. Refer to Page 6 for part interchangeability.

The performance and life of the couplings depend largely upon how you install and service them.

CAUTION: Consult applicable local and national safety codes for proper guarding of rotating members. Observe all safety rules when installing or servicing couplings.

WARNING: Lockout starting switch of prime mover and remove all external loads from drive before installing or servicing couplings.

LUBE FITTINGS

Cover halves have 1/8 NPT lube holes. Use a standard grease gun and lube fitting as instructed on Page 4.

LIMITED END FLOAT

When electric motors, generators, engines, compressors and other machines are fitted with sleeve or straight roller bearings, limited axial end float kits are recommended for protecting the bearings. Falk Steelflex couplings are easily modified to limit end float; refer to Manual 428-820 for instructions.

TYPE T10 STEELFLEX COUPLING

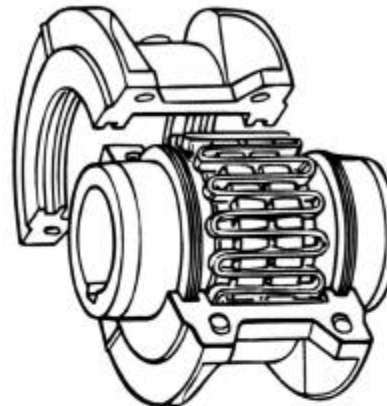

LUBRICATION

Adequate lubrication is essential for satisfactory operation. Page 2 provides a list of typical lubricants and specifications for general purpose and long term greases. Because of its superior lubricating characteristics and low centrifuge properties, Falk Long Term Grease (LTG) is highly recommended. Sizes 1020T to 1090T10 are furnished with a pre-measured amount of grease for each coupling. The grease can be ordered for larger size couplings.

The use of general purpose grease requires re-lubrication of the coupling at least annually.

Long Term Grease (LTG)

The high centrifugal forces encountered in couplings separate the base oil and thickener of general purpose greases. Heavy thickener, which has no lubrication qualities, accumulates in the grid-groove area of Steelflex couplings resulting in premature hub or grid failure unless periodic lubrication cycles are maintained.

Falk Long Term Grease (LTG) was developed specifically for couplings. It resists separation of the oil and thickener and is an extreme pressure grease.

Steelflex couplings initially lubricated with LTG will not require re-lubrication until the connected equipment is stopped for servicing. If a coupling leaks grease, is exposed to extreme temperatures, excessive moisture, or experiences frequent reversals, more frequent lubrication may be required.

Although LTG grease is compatible with most other coupling greases, the mixing of greases may dilute the benefits of LTG.

USDA Approval

LTG has the United States Department of Agriculture Food Safety & Inspection Service approval for applications where there is no possibility of contact with edible products. (H-2 ratings).

CAUTION: Do not use LTG in bearings.

Specifications — Falk LTG

The values shown are typical and slight variations are permissible.
AMBIENT TEMPERATURE RANGE — -20°F (-29°C) to 250°F (121°C). Min. Pump = 20° F (-7° C).

MINIMUM BASE OIL VISCOSITY — 3300SSU (715cST) @ 100°F (38°C).

THICKENER — Lithium & soap/polymer.

CENTRIFUGE SEPARATION CHARACTERISTICS — ASTM #D4425 (Centrifuge Test) — K36 = 2/24 max., very high resistance to centrifuging.

NLGI GRADE (ASTM D-217) — 1/2

MINIMUM DROPPING POINT — with 60 stroke worked penetration value in the range of 320 to 365 — 350°F (177°C) min.

MINIMUM TIMKEN O.K. LOAD — 40 lbs.

ADDITIVES — Rust and oxidation inhibitors that do not corrode steel or swell or deteriorate synthetic seals.

Packaging

14 oz. (0,4 kg) CARTRIDGES — Individual or case lots of 10 or 60.

35 lb. (16 kg) PAIL, 120 lb. (54 kg) KEG & 400 lb. (181 kg) DRUMS.

General Purpose Grease

Annual Lubrication — The following specifications and lubricants for general purpose grease apply to Falk Steelflex couplings that are lubricated annually and operate within ambient temperatures of 0°F to 150°F (-18°C to 66°C). For temperatures beyond this range (see Table 1), consult the Factory.

If a coupling leaks grease, is exposed to extreme temperatures, excessive moisture or experiences frequent reversals, more frequent lubrication may be required.

Specifications — General Purpose Coupling Lubricants

The values shown are typical and slight variations are permissible.

DROPPING POINT — 300°F (149°C) or higher.

CONSISTENCY — NLGI No. 2 with 60 stroke worked penetration value in the range of 250 to 300.

SEPARATION AND RESISTANCE — Low oil separation rate and high resistance to separation from centrifuging.

LIQUID CONSTITUENT — Possess good lubricating properties equivalent to a high quality, well refined petroleum oil.

INACTIVE — Must not corrode steel or cause swelling or deterioration of synthetic seals.

CLEAN — Free from foreign inclusions.

General Purpose Greases Meeting Falk Specifications

Lubricants listed below are typical products only and should not be construed as exclusive recommendations.

TABLE 1 — General Purpose Greases *

Ambient Temperature Range	0°F to 150°F (-18°C to 66°C)	-30°F to 100°F (-34°C to 38°C)
Manufacturer	Lubricant †	Lubricant †
Amoco Oil Co.	Amolith Grease #2	Amolith Grease #2
BP Oil Co.	Energrease LS-EP2	Energrease LS-EP1
Chevron U.S.A. Inc.	Dura-Lith EP2	Dura-Lith EP1
Citgo Petroleum Corp.	Premium Lithium Grease EP2	Premium Lithium Grease EP1
Conoco Inc.	EP Conolith Grease #2	EP Conolith Grease #2
Exxon Company, USA	Unirex N2	Unirex N2
E.F. Houghton & Co.	Cosmolube 2	Cosmolube 1
Imperial Oil Ltd.	Unirex N2L	Unirex N2L
Kendall Refining Co.	Lithium Grease L421	Lithium Grease L421
Keystone Div. (Pennwalt)	B1 EP-2	B1 EP-1
Lyondell Petrochemical (ARCO)	Lithaline H EP 2 Grease	Lithaline H EP 2 Grease
Mobil Oil Corp.	Mobilux EP111	Mobilith AW1
Petro-Canada Products	Multipurpose EP2	Multipurpose EP1
Phillips 66 Co.	Philube Blue EP	Philube Blue EP
Shell Oil Co.	Alvania Grease 2	Alvania Grease 2
Shell Canada Ltd.	Alvania Grease 2	Alvania Grease 2
Sun Oil Co.	Ultra Prestige 2EP	Ultra Prestige 2EP
Texaco Lubricants	Starplex HD2	Multifok EP2
Unocal 76 (East & West)	Unoba EP2	Unoba EP2
Valvoline Oil Co.	Multilube Lithium EP Grease	...

* Grease application or re-lubrication should be done at temperatures above 20°F (-7°C). If grease must be applied below 20°F (-7°C), consult The Falk Corporation.
 † Lubricants listed may not be suitable for use in the food processing industry; check with lube manufacturer for approved lubricants.

INSTALLATION OF TYPE T10 STEELFLEX TAPERED GRID COUPLINGS

Installation

Only standard mechanics tools, wrenches, a straight edge and feeler gauges are required to install Falk Steelflex couplings. Coupling Sizes 1020T thru 1090T are generally furnished for CLEARANCE FIT with setscrew over the keyway. Sizes 1100T and larger are furnished for an INTERFERENCE FIT without a setscrew.

CLEARANCE FIT HUBS — Clean all parts using a non-flammable solvent. Check hubs, shafts and keyways for burrs. Do not heat clearance fit hubs. Install keys, mount hubs with flange face flush with shaft ends or as otherwise specified and tighten setscrews.

INTERFERENCE FIT HUBS — Furnished without setscrews. Heat hubs to a maximum of 275°F (135°C) using an oven, torch, induction heater or an oil bath. To prevent seal damage, DO NOT heat hubs beyond a maximum temperature of 400°F (205°C).

When an oxy-acetylene or blow torch is used, use an excess acetylene mixture. Mark hubs near the center of their length in several places on hub body with a temperature sensitive crayon, 275°F (135°C) melt temperature. Direct flame towards hub bore using constant motion to avoid overheating an area.

WARNING: If an oil bath is used, the oil must have a flash point of 350°F (177°C) or higher. Do not rest hubs on the bottom of the container. Do not use an open flame in a combustible atmosphere or near combustible materials.

Heat hubs as instructed above. Mount hubs as quickly as possible with hub face flush with shaft end. Allow hubs to cool before proceeding. Insert setscrews (if required) and tighten.

Maximize Performance And Life

The performance and life of couplings depend largely upon how you install and maintain them. Before installing couplings, make certain that foundations of equipment to be connected meet manufacturers' requirements. Check for soft foot. The use of stainless steel shims is recommended. Measuring misalignment and positioning equipment within alignment tolerances is simplified with an alignment computer. These calculations can also be done graphically or mathematically. Alignment is shown using spacer bar and straight edge. This practice has proven to be adequate for many industrial applications. However, for superior final alignment, the use of dial indicators (see Manual 458-834 for instructions), lasers, alignment computers or graphical analysis is recommended.

1 — Mount Seals And Hubs

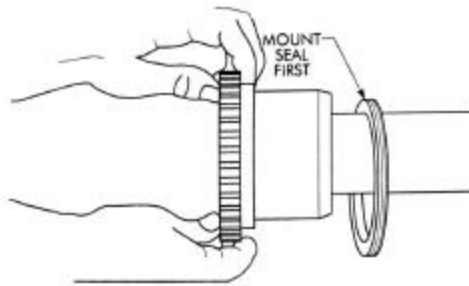

Lock out starting switch of prime mover. Clean all metal parts using a non-flammable solvent. Lightly coat seals with grease and place on shafts BEFORE mounting hubs. Heat interference fit hubs as previously instructed. Seal keyways to prevent leakage. Mount hubs on their respective shafts so the hub face is flush with the end of its shaft unless otherwise indicated. Tighten setscrews when furnished.

2 — Gap and Angular Alignment

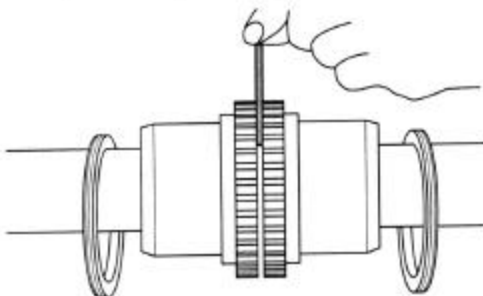

Use a spacer bar equal in thickness to the gap specified in Table 2, Page 5. Insert bar as shown below left, to same depth at 90° intervals and measure clearance between bar and hub face with feelers. The difference in minimum and maximum measurements must not exceed the ANGULAR installation limits specified in Table 2.

3 — Offset Alignment

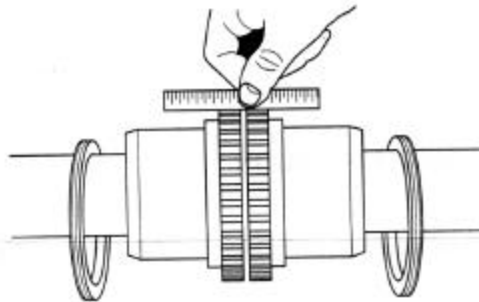

Align so that a straight edge rests squarely (or within the limits specified in Table 2) on both hubs as shown above and also at 90° intervals. Check with feelers. The clearance must not exceed the PARALLEL OFFSET installation limits specified in Table 2. Tighten all foundation bolts and repeat Steps 2 and 3. Realign coupling if necessary.

4 — Insert Grid

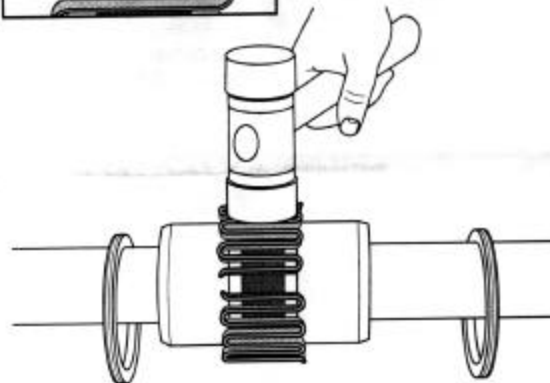
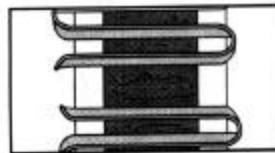

Pack gap and grooves with specified lubricant before inserting grid. When grids are furnished in two or more segments, install them so that all cut ends extend in the same direction (as detailed in the exploded view picture above); this will assure correct grid contact with non-rotating pin in cover halves. Spread the grid slightly to pass over the coupling teeth and seat with a soft mallet.

5 — Pack With Grease And Assemble Covers

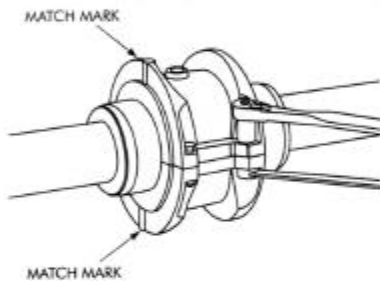
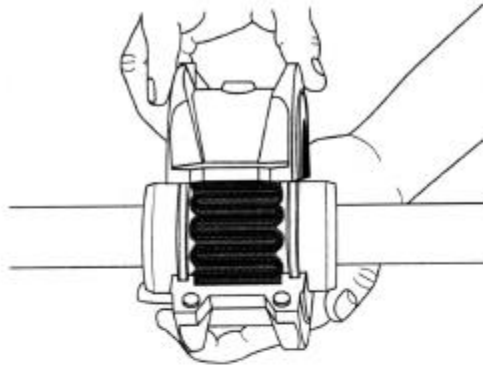

Pack the spaces between and around the grid with as much lubricant as possible and wipe off excess flush with top of grid. Position seals on hubs to line up with grooves in cover. Position gaskets on flange of lower cover half and assemble covers so that the match marks are on the same side (see above). If shafts are not level (horizontal) or coupling is to be used vertically, assemble cover halves with the lug and match mark

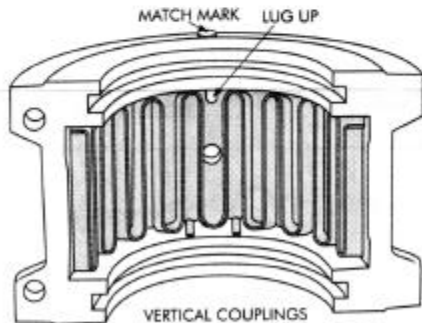

UP or on the high side. Push gaskets in until they stop against the seals and secure cover halves with fasteners, tighten to torque specified in Table 2. Make sure gaskets stay in position during tightening of fasteners. **CAUTION:** Make certain lube plugs are installed before operating.

ANNUAL MAINTENANCE

For extreme or unusual operating conditions, check coupling more frequently.

1. Check alignment per steps on Page 3. If the maximum operating misalignment limits are exceeded, realign the coupling to the recommended installation limits. See Table 2 for installation and operating alignment limits.
2. Check tightening torques of all fasteners.
3. Inspect seal ring and gasket to determine if replacement is required. If leaking grease, replace.
4. When connected equipment is serviced, disassemble the coupling and inspect for wear. Replace worn parts. Clean grease from coupling and repack with new grease. Install coupling using new gasket as instructed in this manual.

Periodic Lubrication

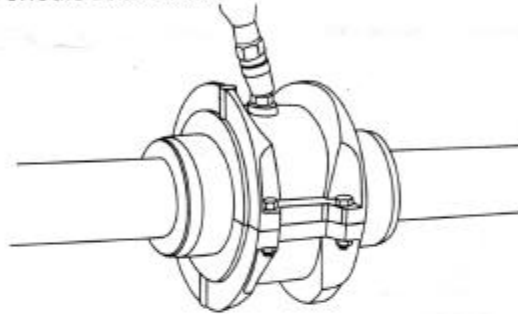

The required frequency of lubrication is directly related to the type of lubricant chosen, and the operating conditions. Steelflex couplings lubricated with common industrial lubricants, such as those shown in Table 1, should be relubed annually. The use of Falk Long Term Grease (LTG) will allow relube intervals to be extended to beyond five years. When relubing, remove both lube plugs and insert lube fitting. Fill with recommended lubricant until an excess appears at the opposite hole. **CAUTION:** Make certain all plugs have been inserted after lubricating.

Coupling Disassembly And Grid Removal

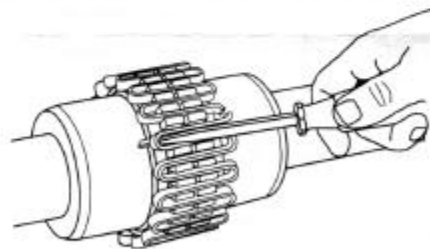

Whenever it is necessary to disconnect the coupling, remove the cover halves and grid. A round rod or screwdriver that will conveniently fit into the open loop ends of the grid is required. Begin at the open end of the grid section and insert the rod or screwdriver into the loop ends. Use the teeth adjacent to each loop as a fulcrum and pry the grid out radially in even, gradual stages, proceeding alternately from side to side.

TYPE T COUPLING INSTALLATION & ALIGNMENT DATA

Maximum life and minimum maintenance for the coupling and connected machinery will result if couplings are accurately aligned. Coupling life expectancy between initial alignment and maximum operating limits is a function of load, speed and lubrication. Maximum operating values listed in Table 2 are based on cataloged allowable rpm.

Values listed are based upon the use of the gaps listed, standard coupling components, standard assemblies and cataloged allowable speeds.

Values may be combined for an installation or operating condition.

Example: 1060T max. operating misalignment is .016" parallel plus .018" angular.

NOTE: For applications requiring greater misalignment, refer application details to the Factory.

Angular misalignment is dimension X minus Y as illustrated below.

Parallel misalignment is distance P between the hub center lines as illustrated below.

End float (with zero angular and parallel misalignment) is the axial movement of the hubs(s) within the cover(s) measured from "O" gap.

ANGULAR MISALIGNMENT

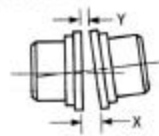

PARALLEL OFFSET MISALIGNMENT

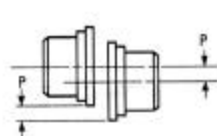

END FLOAT

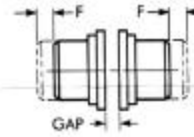

TABLE 2 — Misalignment & End Float

SIZE	Installation Limits						Operating Limits						Cover Fastener Tightening Torque Values		Allow Speed (rpm)	Lube Wt	
	Parallel Offset-P		Angular (x-y)		Hub Gap ± 10%		Parallel Offset-P		Angular (x-y)		End Float Physical Limit (Min) 2 x F		In Series Fasteners (lb-in)	Metric Fasteners (Nm)		lb	kg
	Max Inch	Max mm	Max Inch	Max mm	Inch	mm	Max Inch	Max mm	Max Inch	Max mm	Inch	mm					
1020T	.006	0.15	.003	0.08	.125	3	.012	0.30	.010	0.25	.210	5.33	100	11.3	4500	.06	0.03
1030T	.006	0.15	.003	0.08	.125	3	.012	0.30	.012	0.30	.198	5.03	100	11.3	4500	.09	0.04
1040T	.006	0.15	.003	0.08	.125	3	.012	0.30	.013	0.33	.211	5.36	100	11.3	4500	.12	0.05
1050T	.008	0.20	.004	0.10	.125	3	.016	0.41	.016	0.41	.212	5.38	200	23.6	4500	.15	0.07
1060T	.008	0.20	.005	0.13	.125	3	.016	0.41	.018	0.46	.258	6.55	200	23.6	4350	.19	0.09
1070T	.008	0.20	.005	0.13	.125	3	.016	0.41	.020	0.51	.259	6.58	200	23.6	4125	.25	0.11
1080T	.008	0.20	.006	0.15	.125	3	.016	0.41	.024	0.61	.288	7.32	200	23.6	3600	.38	0.17
1090T	.008	0.20	.007	0.18	.125	3	.016	0.41	.028	0.71	.286	7.26	200	23.6	3600	.56	0.25
1100T	.010	0.25	.008	0.20	.188	5	.020	0.51	.033	0.84	.429	10.90	312	35	2440	.94	0.43
1110T	.010	0.25	.009	0.23	.188	5	.020	0.51	.036	0.91	.429	10.90	312	35	2250	1.1	0.51
1120T	.011	0.28	.010	0.25	.250	6	.022	0.56	.040	1.02	.556	14.12	650	73	2025	1.6	0.74
1130T	.011	0.28	.012	0.30	.250	6	.022	0.56	.047	1.19	.551	14.00	650	73	1800	2.0	0.91
1140T	.011	0.28	.013	0.33	.250	6	.022	0.56	.053	1.35	.571	14.50	650	73	1650	2.5	1.14

TABLE 3 — Coupling Cover Fastener Identification

SIZE	Inch Series Fasteners				METRIC FASTENERS	
	Old Style		New Style			
1020-1070T10		SAE Grade 8 ¹		SAE Grade 8		Property Class 10.9
1080-1090T10		SAE Grade 8		SAE Grade 8		Property Class 10.9
1100-1140T10		SAE Grade 5		SAE Grade 5		Property Class 8.8

* Older style covers, Sizes 1020T10 thru 1070T10 must utilize socket head cap screws and locknuts held by the cover.

PARTS IDENTIFICATION

All coupling parts have identifying part numbers as shown below. Parts 3 and 4 (Hubs and Grids), are the same for both Type T10 and T20 couplings. All other coupling parts are unique to Type T10. When ordering parts, always SPECIFY SIZE and TYPE shown on the COVER.

PARTS INTERCHANGEABILITY

Parts are interchangeable between Sizes 20T and 1020T, 30T and 1030T, etc. except as noted.

GRIDS — Size 1020T thru 1140T Steelflex couplings use blue grids. Older models, 20T thru 140T, use orange grids.

CAUTION: Blue grids may be used in all applications, but DO NOT substitute orange grids for blue.

COVERS — **CAUTION:** DO NOT mix cover halves of different designs. Sizes 1020T thru 1070T10 covers have been manufactured in several different two-rib designs and 80T thru 140T covers have been manufactured with two and three ribs.

HARDWARE — Older style covers, Sizes 1020T10 thru 1070T10, utilized socket head cap screws with captured locknuts. The new style covers use hex head cap screws (either inch or metric) and unrestrained locknuts. Specify either inch series SOCKET head or metric series HEX head cap screws when ordering replacement parts.

PART NUMBER LOCATION

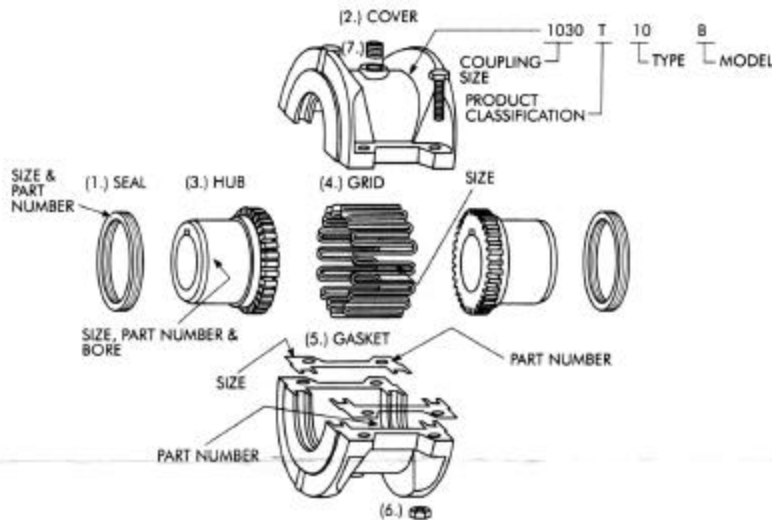

PART DESCRIPTION

1. Seal (T10)
2. Cover (T10)
3. Hub (Specify bore and keyway)
4. Grid
5. Gasket (T10)
6. Fasteners (T10) — Coupling may be supplied with one set each of inch series fasteners and metric fasteners.
7. Lube Plug

ORDER INFORMATION

1. Identify part(s) required by name above.
2. Furnish the following information.

EXAMPLE:

Coupling Size: 1030
Coupling Type: T10
Model: B
Bore: 1.375
Keyway: .375 x .187

3. Price parts from Price List 422-110 and appropriate discount sheet.

OPERATING & MAINTENANCE INSTRUCTIONS

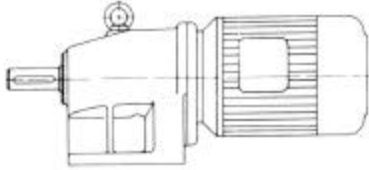

HELICAL

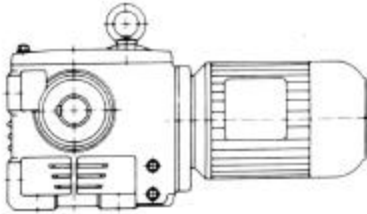

HELICAL-WORM

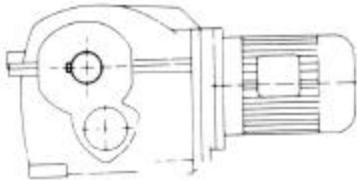

BEVEL-HELICAL

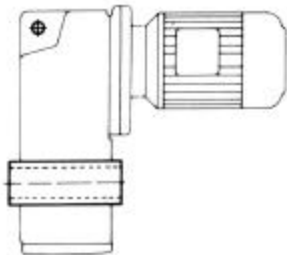

SHAFT MOUNT



NORD GEAR CORPORATION

800 Nord Drive
P.O. Box 367
Wauunakee, WI 53597-0367

Phone (608)849-7300
TWX 910-286-2704
FAX 608-849-7367



318-618/93

INSTALLATION

The gearmotor or reducer should be mounted on a structure with enough rigidity to prevent vibration or flexure caused by dynamic loading. The mounting surface should be flat so stresses are not introduced during assembly of the unit on the structure. Externally mounted gears, sprockets and sheaves should be carefully aligned to prevent stresses caused by poorly aligned members.

If a coupling is used it should be a flexible coupling and the halves should be aligned in accordance with the coupling manufacturer's recommendations.

When mounting anything on the shaft of the gear unit the member should be heated if possible to make assembly easier.

Gears, sprockets or sheaves should be mounted as close to the gear housing as possible. Coupling guards should be provided by the customer.

ELECTRICAL CONNECTIONS

Check the motor nameplate to verify the phase, hertz and voltage agrees with the available power supply. Connection should conform to local codes. A connection diagram for the motor is located inside the conduit box and on the motor nameplate. The motor starter should incorporate an overload protector.

START-UP

All units are lubricated before shipment. The breather is plugged for shipment. Before start-up or prolonged storage remove the plastic wick from the breather. The lubricant level should be checked with the unit mounted in its correct operating position. Lubricant should be added or removed to bring it to the correct level. The catalog for the gear unit shows the oil level for various mounting positions.

MAINTENANCE

A. MOTOR

During maintenance, inspect the fan guard and remove any accumulated debris from under it and around the motor and gear. Motor bearings are greased during assembly. For re-lubrication the following suggestions are offered:

HOURS OF SERVICE PER YEAR	HP RANGE	SUGGESTED RELUBE INTERVAL
5,000	¼ to 7½ 10 to 40 50 to 150	5 years 3 years 1 year
CONTINUOUS Normal Application	¼ to 7½ 10 to 40 50 to 150	2 years 1 year 9 months
SEASONAL SERVICE Motor is idle for 6 months or more	All	1 year (beginning of season)
CONTINUOUS High ambients, dirty or moist locations, high vibrations, or where shaft is hot (pumps—fans).	¼ to 40 50 to 190	6 months 3 months

Use high quality ball bearing grease. Use consistency of grease suitable for class of insulation stamped on nameplate as follows:

INSULATION CLASS	CONSISTENCY	TYPE	TYPICAL	FRAME TYPE
A & B	#2	Lithium Base	Shell Alvania Grease R 3	215 T & smaller
A & B	Medium	Polyurea	Shell Dolium Grease R	254T & larger
F & H	Medium	Polyurea	Shell Dolium Grease R	All

Procedure:

If motor is equipped with Alemite fitting, clean tip of fitting and apply grease gun. Use 1 to 2 full strokes on motors in NEMA 215 frame and smaller. Use 2 to 3 strokes on NEMA 254 through NEMA 365 frame. Use 3 to 4 strokes on NEMA 404 frames and larger. On motors having drain plugs, remove grease drain plug and operate motor for 20 minutes before replacing drain plug.

On motors equipped with slotted head grease screw, remove screw and apply grease tube to hole. Insert 3 to 3 inch length of grease string into each hole on motors in NEMA 215 frame and smaller. Insert 3 to 5 inch length on larger motors. Motors having grease drain plugs, remove plug and operate motor 20 minutes before replacing drain plug.

Caution: Keep grease clean. Lubricate motors at standstill. Remove and replace drain plugs at standstill. Do not mix petroleum grease and silicone grease in motor bearings.

B. GEARS

Gear units should have the oil changed every 10,000 hours or 2 years. If synthetic lubricant is used it should be changed every 20,000 hours or 4 years. For adverse operating conditions the interval should be shorter. DO NOT MIX SYNTHETIC & MINERAL BASE OILS. Units should be checked periodically for increased noise, surface temperature, vibration, shaft movement & amperage draw. Units with inspection covers should not be operated with the inspection cover removed.

The table below offers suggestions on the viscosity & manufacturers of recommended lubricants.

VISCOSITY RANGE FOR AGMA LUBRICANTS

RUST AND OXIDATION INHIBITED GEAR OILS	VISCOSITY RANGE ‡	EQUIVALENT ISO GRADE ◀	EXTREME PRESSURE GEAR LUBRICANTS ‡‡	VISCOSITIES OF FORMER AGMA SYSTEM ◀◀
AGMA Lubricant No.	mm ² /s (cSt) at 40 °C		AGMA Lubricant No.	SSU at 100 °F
1	41.4 to 50.6	46		193 to 235
2	61.2 to 74.8	68	2 EP	284 to 347
3	90 to 110	100	3 EP	417 to 510
4	135 to 165	150	4 EP	626 to 765
5	198 to 242	220	5 EP	918 to 1122
6	288 to 352	320	6 EP	1335 to 1632
7 Comp	414 to 506	460	7 EP	1919 to 2346
8 Comp	612 to 748	680	8 EP	2837 to 3467
8A Comp	900 to 1100	1000	8A EP	4171 to 5098

NOTE: Viscosity ranges for AGMA lubricant numbers will henceforth be identical to those of ASTM 2422.
 ‡ "Viscosity System for Industrial Fluid Lubricants", ASTM 2422. Also British Standards Institute, B.S. 4231.
 ◀ "Industrial Liquid Lubricants—ISO Viscosity Classification." International Standard, ISO 3448.
 ‡‡ AGMA 250.03, May, 1972 and AGMA 251.02, November, 1974.
 ◀◀ Oils marked Comp are compounded with 3% to 10% fatty or synthetic fatty oils.

RECOMMENDED LUBRICANTS FOR HELICAL & BEVEL-HELICAL GEARING

Type of Lubricant	Ambient Temperature Range (°F)	kin Viscosity (cSt) at 40°C (mm 2/S)	Viscosity SUS 175 100°F	AGMA Lubricant No.	ISO Grade	AMOCO	CHEVRON	EXXON	MOBIL	SHELL	TEXACO
Oil	15 to 125	198 to 242	900 to 1100	5EP	220EP	AMOGEAR EP220	NL GEAR Compound 220	SPARTAN EP220	Mobil Gear 630	Omala Oil 220	Meropa 220
	-10 to +75*	90 to 765	465 to 165	3-4EP	100-150EP	AMOGEAR EP150	NL GEAR Compound 150	SPARTAN EP 150	Mobil 629	Omala Oil 100	Meropa 150
	Below 10* ‡‡	15 to 680	135 to 165	—	—	—	E.P. Hydraulic Oil 22	UNIVIS J13	Mobil D.T.E. 11	—	Texamatic Fluid 9226 or Texamatic Type F
Oil—Synthetic	-40* to 175* ‡	—	90 to 4000	—	—	—	—	—	Mobil SHC 629 or 634	—	Synstar GL75W-140
Fluid Grease	5* to 120*	—	—	—	—	—	—	—	—	—	MARKFAK 00

For bearings not lubricated in oil bath use a lithium base bearing grease, NLGI #2 or #3
 ‡ Ambient temperatures below -20°F and above 140°F require special oil seals
 ‡‡ Consult with Nord Gear Corporation for these applications
 Bold ambient temperature indicates factory filled

Actual capacity should be established by opening the oil level plug and filling until oil runs out of the oil level hole.

RECOMMENDED LUBRICANTS FOR HELICAL-WORM GEARING

TYPE OF LUBRICANT	AMBIENT TEMP RANGE °F	KIN VISCOSITY (cSt) AT 40°C (mm 2/S)	VISCOSITY SUS 175 100°F	ISO GRADE	MOBIL	TEXACO
Oil Synthetic	-40* to 175* ‡	198 to 352	900 to 1600	220	Glygoyle 30	Synstar GL75W 140

For bearings not lubricated in oil bath use a lithium base bearing grease, NLGI #2 or #3
 ‡ Ambient temperatures below 0°F and above 100°F require special oil seals
 Consult NORD GEAR CORPORATION for these applications

STORAGE

Units shipped from Nord are intended to be used within 30 days after receipt and presumed to be stored indoors in a heated building. If you intend storing units under adverse conditions or for a long period of time special storage precautions will be necessary.

1. Store in a sheltered area away from chemical vapors or steam.
2. Cover.
3. Do not store in sunlight or near high heat.
4. Remove plastic wick from breather.
5. Spray oil on exposed shafts & seals. Remove oil on start-up.
6. Rotate output shaft 360° every 3-4 weeks.

PILLOW BLOCK MAINTENANCE:

Use standard bearing grease to lube the 2 units on the vertical shaft. Lube at least every 90 days with a standard grease gun.

OPERATING INSTRUCTIONS

1. The Equineciser is designed to exercise horses for conditioning and cooling. The variable speed control is provided to allow the option of adjustment of speed for different horses needs.
2. Horses “DO” require training to walk and behave properly on the exerciser. It is not intended to be used to break wild horses or force them to walk.
3. Screens on each arm are furnished with the Equineciser. They should be inspected once a month, they should be replaced immediately, if the electrical contact to the screen begins to fray. The Quick Links and/or the chain should also be inspected at the same time, the quick links and/or chain should be replaced immediately, if they show signs of weakness or breakage.
4. A monthly check and tightening of all bolted parts is needed on all Quick Links, and all nuts & bolts that attach the rubber mat to the screen.
5. Grease – Grease zerks are located on the vertical shaft. These will grease the moving parts of the drive tower. Greasing every 90 to 120 days is recommended. When greasing use Lithium grease only.
6. Any electrical service should be done by a licensed electrician. 220 Volt wiring is required. NEVER adjust Equineciser speed or put hands near drive assembly unless the electrical switch and the breaker box inside the Equineciser is off.
7. Equinecisers are warranted for one year from the date of purchase as per attached warranty statement.

“DO’S AND DON’TS”

<p>DO NOT attempt to use Equineciser prior to being properly secured to the foundation pad.</p> <p>DO NOT leave the Equineciser unattended while in operation.</p> <p>DO NOT open the cabinet to adjust speed or to turn the power off. Turn power off at the remote switch before opening the cabinet.</p> <p>DO NOT operate the Equineciser with the cabinet off.</p> <p>DO NOT put hands or feet near the drive system while the Equineciser is in operation.</p> <p>DO NOT put more than 1 (one) horse or foal in each moving compartment.</p> <p>DO NOT put studs & mares in exerciser at same time.</p> <p>DO NOT turn electrified divider screens ON after horses are in the exerciser.</p> <p>DO NOT ride or allow a child to ride a horse that is being exercised.</p> <p>DO NOT use your Equineciser as a merry-go-round for children or adults.</p>	<p>DO have all electrical hook-ups done by a licensed electrician.</p> <p>DO have electrified divider screens turned ON before & during the loading & unloading of horses.</p> <p>DO accelerate exerciser slowly & de-accelerate slowly, so that the computer is not damaged, and the horses have time to adjust to the speed.</p> <p>DO allow the Equineciser to stop completely before reversing direction.</p> <p>DO check for electrical charge on each divider screen once a month.</p> <p>DO grease your Equineciser at the grease fittings 90-120 days or more often if the unit is in constant use.</p>
--	--

Use the utmost caution in operating this equipment.

DO NOT allow water or moisture to accumulate around any wiring, switches, or the motor.

Moving parts can be hazardous to a person wearing loosely fitting clothing or with long hair.

All moving parts of this equipment are of heavy gauge steel. DO NOT expose any portion of your body to this equipment while it is in motion.

As with all electrical driven equipment, the utmost caution must be taken with regard to exposure to electrical shock caused through a rupture of any electrical connections or wire.

Control Box Operating Instructions For Free Flow Equinecisers without Optional Timer

1. Turn Power Switch on.
2. Turn Direction Switch to either forward or reverse.
3. Turn Screen Shocker On or Off.
4. Turn dial to desired speed. Gradually
 - **NOTE:** The Speed Knob is time delayed
5. Use On/Off Switch **ONLY** to turn Equineciser On & Off.
6. **ALWAYS TURN SPEED DIAL BACK TO ZERO WHEN DONE**, failure to do so will critically damage the Equineciser and void your warranty.
7. **NEVER** turn Equineciser on if Speed Control is not at Zero.
8. Equineciser **MUST** come to a complete stop **PRIOR** to switching directions. Failure to do so will critically damage the Equineciser and void your warranty.

For questions or service call 1-800-962-8050

Control Box Operating Instructions For Free Flow Equinecisers with Optional Timers **ONLY**

1. Turn Power Switch on.
2. Turn on Timer.
 - Minimum setting for timer **MUST** be 10 minutes or more.
3. Turn dial to desired speed.
 - **NOTE:** The Speed Knob is time delayed.
 - **Never turn Timer off.**
4. Use On/Off Switch **ONLY** to turn Equineciser On & Off.
5. **NEVER** turn Timer back to Zero, doing so will critically damage the Equineciser and void your warranty. Always allow Timer to run down on it's own.
6. Equineciser **MUST** come to a complete stop **PRIOR** to switching directions. Failure to do so will critically damage the Equineciser and void your warranty.

For questions or service call 1-800-962-8050

REPLACEMENT PARTS:

Any parts that become worn or broken can be replaced by calling our Corporate Offices at 1-800-962-8050 or 909-685-7337. Most of the parts can be shipped the same day.

For all remote control units, motors, switches, vari-pulleys, and gearboxes all the model numbers are located on their I.D. plates, for ordering.

Centaur Free Flow Equineciser Limited Warranty

Centaur Five-Year Limited Warranty

Centaur Horse Walkers, Inc warrants that for a period of five (5) years after the date of delivery it will re-supply the following component parts: Falk Collar Coupling, and the Drive System (Gearbox, and Motor) (under normal usage) on their Free Flow Equinecisers Models 300FF, 350FF, 400FF, 450FF, 500FF, 550FF, 600FF and 650FF to the original user against defects in workmanship or materials under normal use, with regular service maintenance of the equineciser sold that prove to be defective in respect to the materials and/or workmanship. The warranty is expressly limited to furnishing (but not dismantling or installing) necessary replacement parts, does not cover or include any consequential damages and does not cover defects or damage caused by acts of God, falling objects, or other accidents or casualties, aggressive atmosphere conditions (including, but not limited to, salt water atmosphere, fallout or exposure to corrosive chemicals, fumes, ash, animal waste, excessive wind and excessive snow loading or the like), improper installation, neglect, negligence abuse or willful damage by Purchaser, this includes attaching objects to the screens and/or the arms, to use to level and/or smooth out the exerciser path, & attaching objects to the screens and/or arms, to use as a weather shade. Any defect or damage covered by this warranty must be reported to Centaur, in writing within 30 days after discovery or this warranty shall be void. It is expressly understood and agreed that any warranty, expressed or implied, shall extend only to structural defects in the material, whether galvanized (optional) or steel (standard), and any component parts appurtenant to the equipment. Any part, which is determined by Centaur to be defective in material or workmanship and returned to our authorized service location, as Centaur designates, shipping costs prepaid by client, will be, as the exclusive remedy, repaired or replaced at Centaur's option. Shipping to be supplied by client on all returning items. For limited warranty, claim procedures see PROMPT DISPOSITION below. This limited warranty gives purchasers specific legal rights, which vary, from state to state. **THIS WARRANTY IS GIVEN EXPRESSLY AND IN PLACE OF ALL OTHER EXPRESS OR IMPLIED WARRANTIES INCLUDING IMPLIED WARRANTIES OF MERCHANTABILITY AND FITNESS FOR A PARTICULAR PURPOSE.**

Centaur One-Year Limited Warranty

Centaur Horse Walkers, Inc warrants that for a period of one (1) year after the date of delivery it will re-supply the following component parts: AC Tech Controller and/or ABB Controller, Remote Control Box, Fence Shocker, and Fencing (under normal usage) on their Free Flow Equinecisers Models 300FF, 350FF, 400FF, 450FF, 500FF, 550FF, 600FF and 650FF to the original user against defects in workmanship or materials under normal use, with regular service maintenance of the equineciser sold that prove to be defective in respect to the materials and/or workmanship. The warranty is expressly limited to furnishing (but not dismantling or installing) necessary replacement parts, does not cover or include any consequential damages and does not cover defects or damage caused by acts of God, falling objects, or other accidents or casualties, aggressive atmosphere conditions (including, but not limited to, salt water atmosphere, fallout or exposure to corrosive chemicals, fumes, ash, animal waste, excessive wind and excessive snow loading or the like), improper installation, neglect, negligence abuse or willful damage by Purchaser, this includes attaching objects to the screens and/or the arms, to use to level and/or smooth out the exerciser path, & attaching objects to the screens and/or arms, to use as a weather shade. Any defect or damage covered by this warranty must be reported to **Centaur**, in writing within 30 days after discovery or this warranty shall be void. It is expressly understood and agreed that any warranty, expressed or implied, shall extend only to structural defects in the material, whether galvanized (optional) or steel (standard), and any component parts appurtenant to the equipment. Any part, which is determined by Centaur to be defective in material or workmanship and returned to our authorized service location, as Centaur designates, shipping costs prepaid by client, will be, as the exclusive remedy, repaired or replaced at Centaur's option. Shipping to be supplied by client on all returning items. For limited warranty, claim procedures see PROMPT DISPOSITION below. This limited warranty gives purchasers specific legal rights, which vary, from state to state. **THIS WARRANTY IS GIVEN EXPRESSLY AND IN PLACE OF ALL OTHER EXPRESS OR IMPLIED WARRANTIES INCLUDING IMPLIED WARRANTIES OF MERCHANTABILITY AND FITNESS FOR A PARTICULAR PURPOSE.**

Mats on the bottom of screens or attached to fence panels do **NOT** come with a warranty. Any part, which is determined by **Centaur** to be defective in material or workmanship and returned to our authorized service location, as **Centaur** designates, shipping costs prepaid by client, will be, as the exclusive remedy, repaired or replaced at **Centaur's** option. Shipping to be supplied by client on all returning items. For limited warranty claim procedures see PROMPT DISPOSITION below. This limited warranty gives purchasers specific legal rights, which vary, from state to state.

Any dispute about quality, condition or workmanship of the goods or otherwise in connection with the terms of this Agreement, shall not entitle the Buyer to reject the goods. In the case of any dispute the Buyer shall take delivery of the goods, pay for the same, and make a claim under the **Centaur's** warranty.

Working Diameter is approximate intended to identify size sold by **Centaur**. Centaur gives no warranty or representation as to exact dimensions of the working diameter, as the same will vary depending upon placement of concrete base.

Limitation of Liability

To the extent allowable under applicable law, **Centaur's** liability for consequential and incidental damages is expressly disclaimed. **Centaur's** liability in all events is limited to, and shall not exceed, the purchase price paid.

Warranty Disclaimer

Centaur has made a diligent effort to illustrate and describe the products in this literature accurately; however such illustrations and description are for the sole purpose of identification, and do not express or imply a warranty that the products are merchantable, or fit for a particular purpose, or that the products will necessarily conform to the illustrations or descriptions.

Product Suitability

Many states and localities have codes and regulations governing sales, construction installation and/or use of products for certain purposes, which may vary from those in neighboring areas. While **Centaur** attempts to assure that its products comply with such codes it cannot guarantee compliance and cannot be responsible for how the product is installed or used. Before purchase and use of our products, please review the product application, and national & local codes and regulations, and be sure that the product, installation, and use will comply with them.

Certain aspects of disclaimers are not applicable to consumer products; e.g., (A) some states do not allow the exclusion or limitation of incidental or consequential damages, so the above limitations or warranty lasts, consequently the limitations may not apply to you; (B) Also, some states do not allow limitations on how long an implied warranty lasts, consequently the above limitations may not apply to you; and (C) by law, during the period of the limited warranty any implied warranties of merchantability or fitness for a particular purpose applicable to consumer products purchased by consumer, may not be excluded or otherwise disclaimed.

Prompt Disposition

Centaur will in good faith effort for prompt correction or other adjustment with respect to any product, which proves to be defective within limited warranty. For any product believed to be defective within limited warranty, first write or call dealer from whom product was purchased. Dealer will be given additional directions. If unable to resolve satisfactorily write to **Centaur Horse Walkers, Inc.** 5761 Ridgeview Ave., Mira Loma, Ca. 91752, giving dealer's name, address, date and number of dealer's invoice, and describing the nature of the defect. Title and risk of loss pass to buyer on delivery to common carrier. If product was damaged in transit you, file claim with freight carrier.